



**BOARD OF COUNTY COMMISSIONERS
WARREN COUNTY, OHIO**

406 Justice Drive, Lebanon, Ohio 45036

www.co.warren.oh.us

commissioners@co.warren.oh.us

Telephone (513) 695-1250

Facsimile (513) 695-2054

TOM GROSSMANN

SHANNON JONES

DAVID G. YOUNG

GENERAL SESSION AGENDA

December 5, 2023

- | | | |
|----|------|--|
| #1 | | <i>Clerk — General</i> |
| #2 | 9:00 | <i>Bill Kennedy, Chief Archeologist Ohio History Connection – Recognize Ohio Earthworks Site on Becoming a World Heritage Site</i> |
| #3 | 9:05 | <i>Michael Coyan, Warren County Historical Society</i> |
| #4 | 9:15 | <i>Consider Expedited Type 2 Annexation of 0.8143 Acres to the City of South Lebanon, Richard Paolo, Agent</i> |
| #5 | 9:30 | <i>Work Session—2024 Budget</i> |

The Board of Commissioners' public meetings can now be streamed live at [Warren County Board of Commissioners - YouTube](#)

APPROVE REQUISITIONS AND AUTHORIZE DEPUTY COUNTY ADMINISTRATOR TO SIGN DOCUMENTS RELATIVE THERETO

BE IT RESOLVED, to approve requisitions as listed in the attached document and authorize Martin Russell, Deputy County Administrator, to sign on behalf of this Board of County Commissioners.

M moved for adoption of the foregoing resolution being seconded by M. Upon call of the roll, the following vote resulted:

M
M
M

Resolution adopted this 24th day of October 2023.

BOARD OF COUNTY COMMISSIONERS

Tina Osborne, Clerk

/tao

cc: Commissioners' file

REQUISITIONS

Department	Vendor Name	Description	Amount
WAT	KARL ERICH ROSE	WAT FURNISH AND INSTALL SERVIC	\$ 42,270.00 *Install service body on truck
FAC	POWELL COMPANY INC	FAC FLOOR SCRUBBER	\$ 10,159.51 *Capital purchase
SHE	DAN CUMMINS AUTO GROUP LLC	SHE 2023 DURANGO PURSUIT VEHIC	\$ 218,475.40 *Lower than state contract
FAC	RJE BUSINESS INTERIORS CINCINNATI OH INC	FAC OFFICE FURNITURE REPLACEME	\$ 61,276.23 *State contract

PO CHANGE ORDERS

Department	Vendor Name	Description	Amount
WAT	WARREN COUNTY ENGINEER	KING AVE BRIDGE PROJECT	\$ 44,822.71 DECREASE
ENG	EAGLE BRIDGE CO	KING AVE BRIDGE PROJECT	\$ 1,046,887.31 DECREASE

12/5/2023 APPROVED

Martin Russell, Deputy County Administrator

CONSENT AGENDA*

December 5, 2023

Approve the minutes of the November 28, 2023, Commissioners' Meeting.

PERSONNEL

1. *Accept resignation of Ashleigh Blair within Children Services*

GENERAL

2. *Approve renewal of consulting agreement with Horan Associates relative to the 2024 Healthcare Plan*
3. *Authorize County Administrator to sign application with HCC Life Insurance Company for the provision of Stop Loss Coverage*
4. *Set public hearing to consider text amendments to the Warren County Rural Zoning Code*
5. *Authorize W/S Department to initiate contract negotiations with Jones and Henry Engineers, LTD. relative to the Design Improvements to the Lower Little Miami and Waynesville Regional Wastewater Treatment Plants Project*
6. *Advertise for bids for the Middletown Junction Production Well Drilling and Construction Project on behalf of W/S*
7. *Enter classroom training agreement on behalf of OhioMeansJobs Warren County*
8. *Authorize the Sheriff to approve addendum to contract with St. Margaret of York*
9. *Enter into professional service agreement with Environmental Educators, Inc. relative to the Solid Waste Management District's educational program*
10. *Authorize President of the Board to sign the Ohio EPA scrap tire removal certifications and consent form*
11. *Authorize acceptance of quote from Business Communications Specialists on behalf of Telecommunications*
12. *Authorize the President of the Board to sign the 2024 Urban Transit Program and the Elderly and Disabled Fare Assistance Program Grant Contract with ODOT*
13. *Declare various items as a surplus and authorize disposal through internet auction*
14. *Acknowledge approval of financial transactions*
15. *Acknowledge payment of bills*
16. *Approve various performance bond agreements, releases, and street acceptances*
17. *Approve final plats*

FINANCIAL

18. *Approve supplemental appropriation into General Fund 11011110*
19. *Approve appropriation adjustments within Common Pleas, County Court, Information Technology, Building and Zoning, Grants, Mary Haven, and Sewer Revenue*

**Please contact the Commissioners' Office at (513) 695-1250 for additional information or questions on any of the items listed on the Consent Agenda*

December 5, 2023

FOR CONSIDERATION NOT ON CONSENT AGENDA

1. Authorize County Administrator to sign a Memorandum of Understanding between the Warren County Sheriff and the Warren County Sheriff's Office Benevolent Association
2. Authorize the Board to proceed with and not opt- out of settlement agreements with 3M and DuPont as a partial settlement of Warren County's claims in PFAS litigation

AUTHORIZE TIFFANY ZINDEL, COUNTY ADMINISTRATOR TO SIGN A
MEMORANDUM OF UNDERSTANDING BETWEEN THE WARREN COUNTY SHERIFF
AND THE WARREN COUNTY SHERIFF'S OFFICE BENEVOLENT ASSOCIATION

BE IT RESOLVED, to authorize Tiffany Zindel, County Administrator to sign a Memorandum of Understanding between the Warren County Sheriff and the Warren County Sheriff's Office Benevolent Association, regarding the acknowledgement of modification, enhancement and clarification of certain articles and sections of the current Sworn Deputies Collective Bargaining Agreement, SERB Case Number 2022-MED-07-0696 as they may apply to newly hired employee, or the transition of a current Sheriff's Office employee into the position of deputy sheriff, said Memorandum of Understanding is attached here to and made a part hereof.

M. moved for adoption of the foregoing resolution, being seconded by M. Upon call of the roll, the following vote resulted:

M
M
M

Resolution adopted this ___ day of _____ 2023.

BOARD OF COUNTY COMMISSIONERS

Tina Osborne, Clerk

cc: Sheriff (file)

NOV 30 2023 RCMD

RECEIVED 01806006

MEMORANDUM OF UNDERSTANDING

In an attempt to encourage the progressive recruiting of exceptional candidates for the open position of Deputy Sheriff, there are times when the Sheriff may have the ability to send a candidate to the Ohio Basic Peace Officer Academy. This Memorandum of Understanding is designed to modify, enhance or clarify certain articles and sections of the current Sworn Deputies Collective Bargaining Agreement, SERB Case Number 2022-MED-07-0696 as they may apply to a newly hired employee, or the transition of a current Sheriff's Office employee into the position of deputy sheriff. This "Program" is designed to benefit both existing employees in career development and the Sheriff's Office in recruitment. While it is not exclusive to existing employees, they are the emphasis.

1. The determination of when to open this opportunity is strictly at the sole discretion of the Sheriff. When making this decision he may consider many factors to include, but not limited to:
 - Available candidate pool
 - Number of positions needed to be filled
 - Timeliness of academy opening

A decision by the Sheriff to select or not select a candidate for the Ohio Basic Peace Officer Academy is not subject to the grievance procedure.

2. To ensure consistency in the hiring process, Warren County Sheriff's Office Policy and Procedure, *32 Hiring Process* will be adhered to.
3. Addition to Article 7 Probationary Periods:

Section 7.5. The employee, while attending the Basic Peace Officer Academy, is on probation. They may be terminated at any time they are in the Academy and shall have no right to appeal the termination. The 365 calendar day probationary period set forth in Section 7.1 shall apply to all employees subject to this memorandum of understanding and shall commence on the first day the employee works for the Sheriff's Office as a sworn deputy after completing the academy.

4. In the event the selected employee fails to meet academy standards, and they previously filled a role within the Sheriff's Office, there is no guarantee there will be an available opening for them to return to; however, the Sheriff's Office will attempt to accommodate a return to their original assignment. In the event there is no opening, and they are an employee in good standing, the Sheriff may rank them on an available eligibility list for the next available original assignment.

5. Article 15 Clarification:

The Sheriff's Office may use a variety of State Certified Peace Officer Academies and pay for tuition if applicable. Sections 15.2 and 15.5 are applicable. In the event the academy is closed, or the work week does not total 40 hours, or 80 hours in a pay period, the employee is expected to alert the Administrative Services Commander for guidance.

In the event the employee wishes to attend another State Certified Peace Officer Academy, they may coordinate this through the Administrative Services Commander; however, the academy must be the equivalent of a "full-time" academy and will be at their expense. Again, Sections 15.2 and 15.5 are applicable.

6. All equipment needed for the academy will be provided by the Sheriff's Office.

7. Article 23 Wages and Compensation are applicable, and an employee permitted to attend the academy shall be paid at the entry level pay set forth in the sworn deputies' agreement. Upon successful completion of the academy, pay will be commensurate with time in service at the Warren County Sheriff's Office. Date of Hire for purposes of seniority will be calculated from the first full pay period including the academy start date.

8. Article 26 Holidays-The employee will be a continuous employee during the duration of the academy.

9. Article 27 Sick Leave-In the event the employee fails to meet the required attendance policy of the academy due to illness or injury, they must, on their own and at their expense, facilitate making up the hours or be terminated from the program.

10. Addition to Article 34 Disability Leave:

Section 34.8. In the event the employee fails to complete the academy within twelve (12) months from date of hire due to disability, they will be terminated.

11. Employees moving from the non-sworn bargaining unit to the sworn bargaining unit will retain service credit with the Sheriff's Office for purposes of vacation accrual.

12. Employees who were in a non-sworn position prior to entering the academy and do not successfully complete the probationary period as a sworn deputy have no right to return to their former non-sworn position although they shall be considered for a vacancy in the classification held prior to entering the academy. An employee returned to a former classification pursuant to this memorandum shall be credited with the seniority they had at the time they left the bargaining unit but shall not be given credit for time spent in a sworn deputy classification.

13. All other provisions of the current Sworn Deputies Collective Bargaining Agreement are in enforce and effect.

For the Warren County Sheriff's Office:

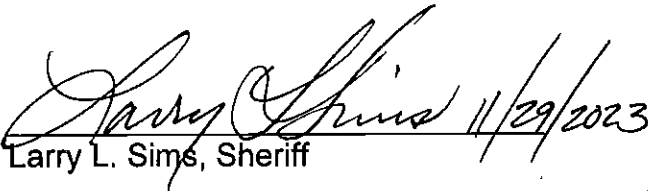

Larry L. Sims, Sheriff

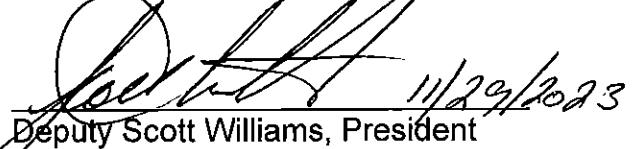
For the Warren County Deputy Sheriff's Benevolent Association:

Deputy Scott Williams, President

For the Warren County Commissioners:

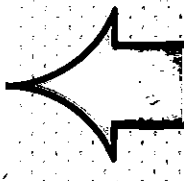
Tiffany Zindel, County Administrator



AUTHORIZING THE BOARD TO PROCEED WITH AND NOT OPT-OUT OF SETTLEMENT AGREEMENTS WITH 3M AND DUPONT AS A PARTIAL SETTLEMENT OF WARREN COUNTY'S CLAIMS IN PFAS LITIGATION

WHEREAS, this Board retained legal counsel who initiated litigation on its behalf which was captioned *Board of County Commissioners of Warren County, Ohio v. 3M Company, et al*, in the Warren County Court of Common Pleas, docketed as Case No. 23CV096288; and,

WHEREAS, the litigation has been removed to the United States District Court for the Southern District of Ohio, Western Division, docketed as Case No. 1:23-CV-512; and,

WHEREAS, while the litigation is not certified as a class action, to date the parties have negotiated separate class settlements with Defendant, 3M Company ("3M") and Defendants The Chemours Company, The Chemours Company FC, LLC, DuPont de Nemours, Inc., Corteva, Inc., and E.I. DuPont de Nemours and Company n/k/a EIDP, Inc. (collectively "DuPont"); and,

WHEREAS, the deadline to opt-out of the 3M settlement is December 11, 2023 and December 4, 2023, for the DuPont settlement; and,

WHEREAS, upon advice of legal counsel, the Board desires not to opt-out of the settlement agreements and proceed with filing claims in both the 3M and DuPont settlements.

NOW THEREFORE BE IT RESOLVED, by the Board of County Commissioners of Warren County, Ohio, at least a majority of all its members casting a vote concur as follows:

- 1) The Board approves proceeding with the settlement agreements with DuPont (and entities related thereto) and 3M, and further authorizes its legal counsel not to opt-out of either settlement agreement and to take all necessary steps for Warren County to participate in the claims process associated with each settlement.
- 2) The Board further authorizes the County Administrator to execute any and all documents in furtherance of the same.
- 3) The findings made by the Board in the above whereas clauses are adopted as a part of these resolving paragraphs.
- 4) All action taken relating hereto and this Resolution is an administrative act.
- 5) All action taken relating hereto to and this Resolution occurred in an open meeting of the Board in compliance with the Ohio Open Meetings Act, Section 121. 22, et seq. of the Ohio Revised Code.

_____ moved for adoption of the foregoing resolution being seconded by _____
 _____. Upon call of the roll, the following vote resulted:

Mrs. Jones – yea
 Mr. Young – yea
 Mr. Grossmann – yea

RESOLUTION #23-_____
DECEMBER 5, 2023
PAGE 2

Resolution adopted this 5th day of December, 2023.

BOARD OF COUNTY COMMISSIONERS

Tina Osborne, Clerk

CERTIFICATION

I hereby certify that the foregoing is a true, accurate, and complete copy of Resolution No. 23-_____ adopted December 5, 2023, by the Board of Commissioners of Warren County, Ohio.

BOARD OF COUNTY COMMISSIONERS

Tina Osborne, Clerk

cc: David Fornshell, Prosecutor
Bruce McGary, Asst. Prosecutor
C/A—Baron & Budd, P.C.
Cossich, Sumich, Parsiola & Taylor LLC
Markovits, Stock & DeMarco, LLC
McNamee & McNamee, LLP
Oths, Heiser, Miller, Waigand & Clagg, LLC



**BOARD OF COUNTY COMMISSIONERS
WARREN COUNTY, OHIO**

406 Justice Drive, Lebanon, Ohio 45036

www.co.warren.oh.us

commissioners@co.warren.oh.us

Telephone (513) 695-1250

Facsimile (513) 695-2054

**TOM GROSSMANN
SHANNON JONES
DAVID G. YOUNG**

BOARD OF COUNTY COMMISSIONERS
WARREN COUNTY, OHIO

MINUTES: Regular Session – November 28, 2023

This is a summary of actions and discussions of the meeting. You may view this meeting through our YouTube Channel at <https://www.youtube.com/channel/UC1ELh0jGpXd4VV2DTgsuqPA> or by contacting our office.

The Board met in regular session pursuant to adjournment of the November 21, 2023, meeting.

Shannon Jones – present

Tom Grossmann – present

David G. Young – present

Tina Osborne, Clerk – present

Minutes of the November 21, 2023, meeting were read and approved.

- 23-1588 A resolution was adopted to approve promotion of Arlis Shane Ammons to the position of Sewer Collections Worker III within the Water and Sewer Department. Vote: Unanimous
- 23-1589 A resolution was adopted to accept resignation of Abbie Downey, Training Coordinator, within the Warren County Department of Job and Family Services, Children Services Division, effective December 5, 2023. Vote: Unanimous
- 23-1590 A resolution was adopted to accept resignation of Alex Hobbs, Control Systems Technician II, within Warren County Water and Sewer Department effective November 24, 2023. Vote: Unanimous
- 23-1591 A resolution was adopted to approve appointment of James Lyons to fill the unexpired term of Jeff Harris as Warren County Apiary Inspector. Vote: Unanimous
- 23-1592 A resolution was adopted to authorize the Water and Sewer Department to enter into negotiations with Wessler Engineering for the design of the Middletown Junction Wellfield Development Project. Vote: Unanimous

MINUTES

NOVEMBER 28, 2023

PAGE 2

- 23-1593 A resolution was adopted to enter into contract with Larry Smith Incorporated for the Pekin Road at State Route 123 Watermain Replacement Project.
Vote: Unanimous
- 23-1594 A resolution was adopted to approve agreement and addendum with Just Like Us Enrichment Agency relative to home placement and related services on behalf of Warren County Children Services. Vote: Unanimous
- 23-1595 A resolution was adopted to enter into classroom training agreement on behalf of OhioMeansJobs Warren County. Vote: Unanimous
- 23-1596 A resolution was adopted to enter into agreement with eGroup Holding Company, LLC on behalf of Warren County Telecommunications.
Vote: Unanimous
- 23-1597 A resolution was adopted to acknowledge approval of financial transactions.
Vote: Unanimous
- 23-1598 A resolution was adopted to acknowledge payment of bills. Vote: Unanimous
- 23-1599 A resolution was adopted to approve various Record Plats. Vote: Unanimous
- 23-1600 A resolution was adopted to approve supplemental appropriation into Commissioners Fund #11011110. Vote: Unanimous
- 23-1601 A resolution was adopted to approve appropriation adjustment from Commissioners General Fund #11011110 into Emergency Services Fund #11012850. Vote: Unanimous
- 23-1602 A resolution was adopted to approve appropriation adjustment within the Sheriff's Office Fund 11012200. Vote: Unanimous
- 23-1603 A resolution was adopted to approve appropriation adjustments within the Sheriff's Office Fund 11012200 and from 11012210 into 11012200.
Vote: Unanimous
- 23-1604 A resolution was adopted to approve appropriation adjustment withing Telecommunications Department Fund #11012810. Vote: Unanimous
- 23-1605 A resolution was adopted to approve appropriation adjustment within Law Library Resources Fund 2207. Vote: Unanimous
- 23-1606 A resolution was adopted to approve appropriation adjustment within Children Services Fund #2273. Vote: Unanimous
- 23-1607 A resolution was adopted to approve appropriation adjustments within Sheriff's Office Fund #6630. Vote: Unanimous

MINUTES

NOVEMBER 28, 2023

PAGE 3

23-1608 A resolution was adopted to approve requisitions and authorize Deputy County Administrator to sign documents relative thereto. Vote: Unanimous

23-1609 A resolution was adopted to approve appropriation adjustments within Board of Elections Fund #11011300. Vote: Unanimous

DISCUSSIONS

On motion, upon unanimous call of the roll, the Board accepted and approved the consent agenda.

ADMINISTRATIVE HEARING
REOPEN SITE PLAN REVIEW APPLICATION OF SHAKER WOODS
IN TURTLECREEK TOWNSHIP

The Board met this 28th day of November 2023, in the Commissioners' Meeting Room to reconsider the site plan review application of Shaker Woods in Turtlecreek Township.

Commissioner Jones acknowledged receipt of a letter from the attorney for the applicant requesting the site plan review application be withdrawn.

Upon further discussion, on motion, upon call of the roll, the Board closed the administrative hearing and accepted the withdrawal of the application.

The Board conducted a work session in the Commissioners' Conference room to discuss the 2024 annual budget.

On motion, upon unanimous call of the roll, the Board entered into executive session at 9:20 a.m. to discuss pending litigation with legal counsel present pursuant to Ohio Revised Code Section 121.22 (G) (3) and exited at 10:45 a.m.

Upon motion the meeting was adjourned.

Shannon Jones, President

David G. Young

Tom Grossmann

I hereby certify that the foregoing is a true and correct copy of the minutes of the meeting of the Board of County Commissioners held on November 28, 2023, in compliance with Section 121.22 O.R.C.

Tina Osborne, Clerk
Board of County Commissioners
Warren County, Ohio

WARREN COUNTY AUDITOR

406 JUSTICE DRIVE, LEBANON, OHIO 45036

MATT NOLAN

AUDITOR

mnolan@wcauditor.org

(513) 695-1235

www.wcauditor.org

Signature Authorization Form For Payroll Functions

Department: Human Services

Three-Character Department Code: HUM

Date: _____

Approved by: *
Signature of Elected Official or Board of Directors Resolution Attached

The following employees are authorized for the corresponding payroll responsibility listed below:

1. Authorized to sign payroll vouchers and vacation/sick leave pay out form:

Arlene Byrd James Ryan Lisa Watson Svetlana Lytrunyk Kiley Danc
Arlene Byrd JRS Lisa Watson Svetlana Lytrunyk Kiley Danc

2. Authorized to sign payroll maintenance forms:

Arlene Byrd James Ryan Lisa Watson Svetlana Lytrunyk Kiley Danc
Arlene Byrd JRS Lisa Watson Svetlana Lytrunyk Kiley Danc

3. Authorized to request Munis user permissions:

Arlene Byrd James Ryan Lisa Watson Svetlana Lytrunyk Kiley Danc
Arlene Byrd JRS Lisa Watson Svetlana Lytrunyk Kiley Danc

WARREN COUNTY AUDITOR

406 JUSTICE DRIVE, LEBANON, OHIO 45036

MATT NOLAN

AUDITOR

mnolan@wcauditor.org

(513) 695-1235

www.wcauditor.org

Signature Authorization Form For Accounting Functions

Department: Human Services

Three-Character Department Code: HUM

Date: _____

Approved by: X
Signature of Elected Official or Board of Directors Resolution Attached

The following employees are authorized for the corresponding accounting responsibility listed below:

1. Authorized to sign adjustment of receipts, adjustment of expenses, intercounty transfers, project adjustments:

Arlene Byrd James Ryan Lisa Walton Svetlana Lytruyuk Kiley Dane
Arlene Byrd JRS Lisa Walton Svetlana Lytruyuk Ki D

2. Authorized to request Munis user permissions:

Arlene Byrd James Ryan Lisa Walton Svetlana Lytruyuk Kiley Dane
Arlene Byrd JRS Lisa Walton Svetlana Lytruyuk Ki D



**REQUEST FOR AUTHORIZATION TO ATTEND ASSOCIATION MEETING,
CONVENTION OR TRAINING SEMINAR/SESSION**

This form is to be completed by Department Head/Elected Official requesting authorization to attend an Association Meeting or Convention or Training Seminar/Session sponsored by an Association as required by O.R.C. Section 325.20. Additionally, authorization is required for any training seminar/session held more than 250 miles from county campus;

*NAME OF ATTENDEE: MICHELLE TEGTMEIER DEPARTMENT: BUILDING/ZONING

*POSITION: DIRECTOR

DATE: 11/16/23

REQUEST FOR AUTHORIZATION FOR THE ABOVE-NAMED EMPLOYEE/ELECTED OFFICIAL TO ATTEND THE FOLLOWING:

ASSOCIATION MEETING CONVENTION ASSOCIATION SPONSORED TRAINING SEMINAR/SESSION
TRAINING MORE THAN 250 MILES

PURPOSE:

ECONOMIC & HOUSING FORECAST 2024

LOCATION:

7518 BALES STREET 120A LIBERTY TOWNSHIP, OHIO 45069

DATE(S):

TYPE OF TRAVEL: (Check one)

AIRLINE STAFF CAR PRIVATE VEHICLE OTHER

LODGING: N/A

ESTIMATED COST OF TRIP: \$35.00 X 2 = \$70.00

I CERTIFY THAT DIRECTION HAS BEEN GIVEN TO ALL EMPLOYEES ATTENDING THIS FUNCTION, THAT IT IS EXPECTED OF THEM TO ATTEND APPLICABLE SESSIONS.

DEPARTMENT HEAD/ELECTED OFFICIAL REQUESTING AUTHORIZATION:

Michelle Tegtmeier Director 11/17/23
Signature/Title Date

BOARD OF COMMISSIONERS' APPROVAL:

Commissioner Date

Commissioner Date

Commissioner Date

*If additional employees will be attending the Association Meeting, Convention or Training Seminar/Session please list names and positions here:

RAY DRATT

11/17/23 10:00 AM

11/17/23 10:00 AM



**REQUEST FOR AUTHORIZATION TO ATTEND ASSOCIATION MEETING,
CONVENTION OR TRAINING SEMINAR/SESSION**

This form is to be completed by Department Head/Elected Official requesting authorization to attend an Association Meeting or Convention or Training Seminar/Session sponsored by an Association as required by O.R.C. Section 325.20. Additionally, authorization is required for any training seminar/session held more than 250 miles from county campus;

*NAME OF ATTENDEE: Michael Wyatt DEPARTMENT: Sheriff's Office

*POSITION: Detective DATE: 11/21/23

REQUEST FOR AUTHORIZATION FOR THE ABOVE-NAMED EMPLOYEE/ELECTED OFFICIAL TO ATTEND THE FOLLOWING:

ASSOCIATION MEETING CONVENTION ASSOCIATION SPONSORED TRAINING SEMINAR/SESSION
TRAINING MORE THAN 250 MILES

PURPOSE:
Attend training related to his job duties.

LOCATION:
Charleston, NC
SC (SP)

DATE(S): 4/15-4/19/24

TYPE OF TRAVEL: (Check one)

AIRLINE STAFF CAR PRIVATE VEHICLE OTHER

LODGING: Residence Inn

ESTIMATED COST OF TRIP: \$3000

I CERTIFY THAT DIRECTION HAS BEEN GIVEN TO ALL EMPLOYEES ATTENDING THIS FUNCTION, THAT IT IS EXPECTED OF THEM TO ATTEND APPLICABLE SESSIONS.

DEPARTMENT HEAD/ELECTED OFFICIAL REQUESTING AUTHORIZATION:

Sherry... 11/27/2023
Signature/Title Date

BOARD OF COMMISSIONERS' APPROVAL:

Commissioner Date

Commissioner Date

Commissioner Date

*If additional employees will be attending the Association Meeting, Convention or Training Seminar/Session please list names and positions here:

[Empty box for listing additional attendees]

RECEIVED 01/23/2024

NOV 27 2023 RCM



HOPEWELL CEREMONIAL EARTHWORKS

Ohio's Hopewell Earthworks and UNESCO World Heritage

WORLD
HERITAGE
OHIO

UNESCO: United Nations Educational, Scientific, and Cultural Organization

- The *UNESCO World Heritage* Program
- Founded 1970s with US Leadership
- Inspired by USA and our Park System
- All nations participate
- 10 criteria: natural and/or cultural sites
- *Outstanding Universal Value to all of Humanity*

A WORLD HERITAGE STORY

“Certain places on Earth are of outstanding universal value and should therefore form part of the common heritage of humankind.”

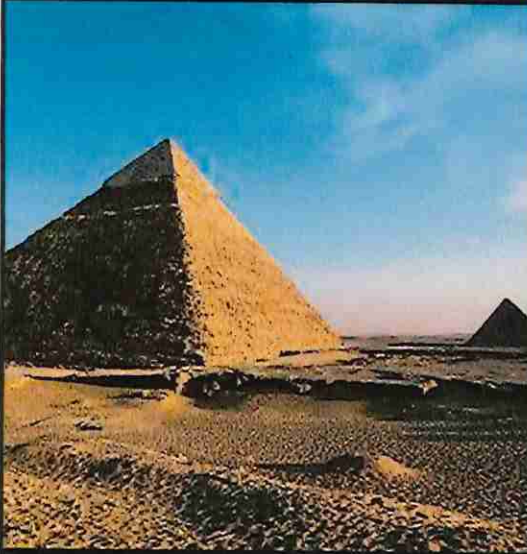

Giza, Egypt



Paestum, Italy

... and over 1,000 more.

Machu Picchu, Peru

Ohio's Hopewell Earthworks and UNESCO World Heritage

WORLD
HERITAGE
OHIO

1000+ WORLD HERITAGE SITES WORLDWIDE



As of September 2023, 25 in the U.S....

Ohio's Hopewell Earthworks and UNESCO World Heritage

WORLD
HERITAGE
OHIO

extent of burial mound construction 700bc-3000 ad
 extent of Hopewellian complexes
 Adams-Hopewell heartland
 and sites 700-1000 bc
 Adams
 other site
 and sites 1000c-1000bc
 Ohio Hopewell
 Armstrong Hopewellian
 New York Hopewellian
 Havana Hopewellian
 Goodall Hopewellian
 Trempealeau Hopewellian
 Crab Orchard Hopewellian
 Kansas City Hopewellian
 Cooper Hopewellian
 Marksville Hopewellian
 Miller Hopewellian
 Porter Hopewellian
 other site
 Effigy Mound site (after 800 bc)
 source of raw material for trade

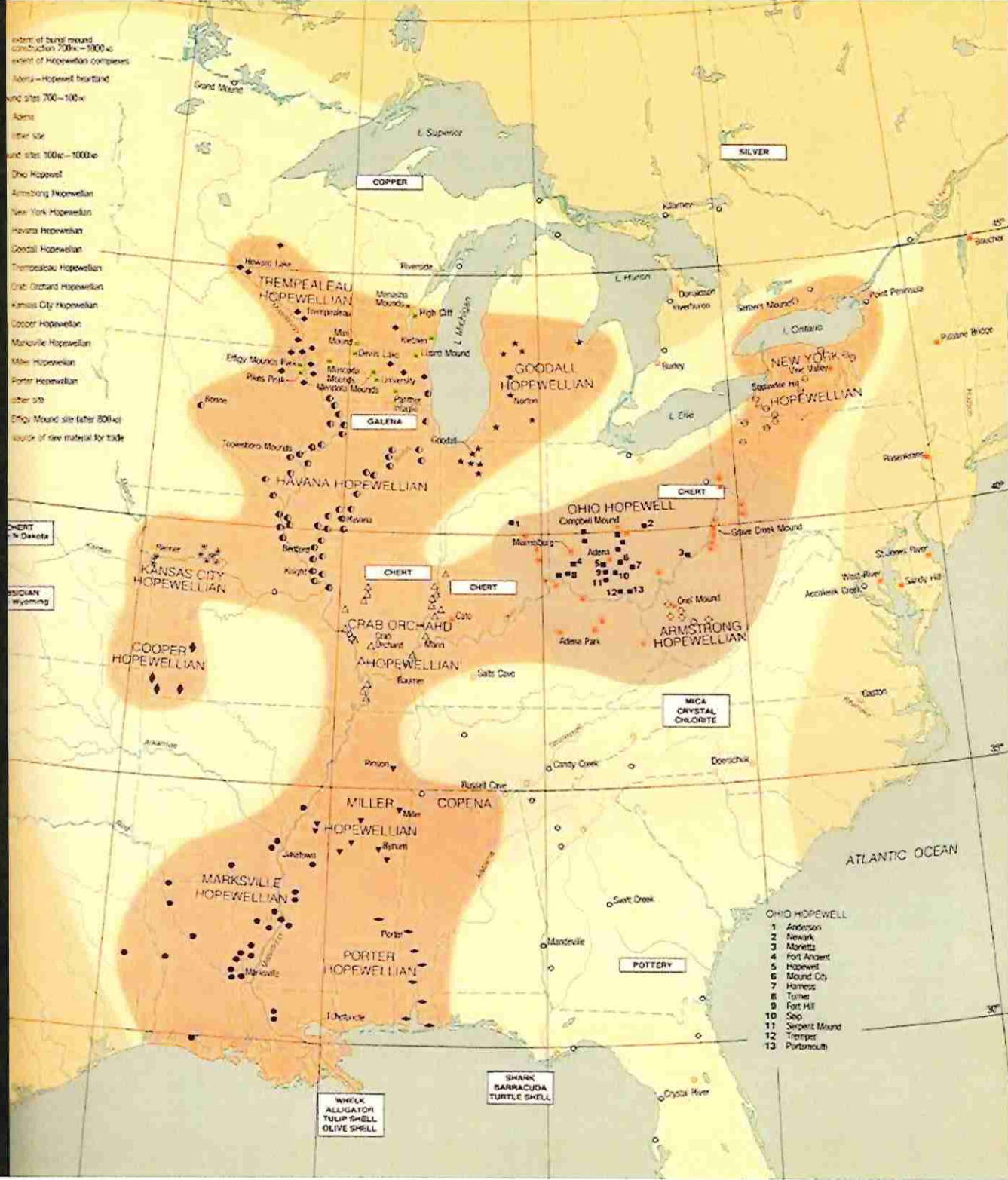

- OHIO HOPEWELL
- 1 Anderson
 - 2 Newark
 - 3 Mounds
 - 4 Fort Ancient
 - 5 Hopewell
 - 6 Mound City
 - 7 Harness
 - 8 Tanne
 - 9 Fort Hill
 - 10 Sep
 - 11 Serpent Mound
 - 12 Tremper
 - 13 Portsmouth

WHEAT
 ALLIGATOR
 TULIP SHELL
 OLIVE SHELL

SHANK
BARRACUDA
TURTLE SHELL

POTTERY

MICA
CRYSTAL
CHLORITE

CHERT

CHERT

CHERT

CHERT
Dakota

OSIDIAN
Wyoming

SILVER

COPPER

Grand Mound

L. Superior

Riverside

L. Michigan

High Cliff

L. Erie

Goodall

Goodall

Goodall

Havana

Havana

Havana

Havana

Havana

Havana

Havana

Havana

Havana

Havana

Havana

Havana

Havana

Havana

Havana

Havana

Havana

Havana

Havana

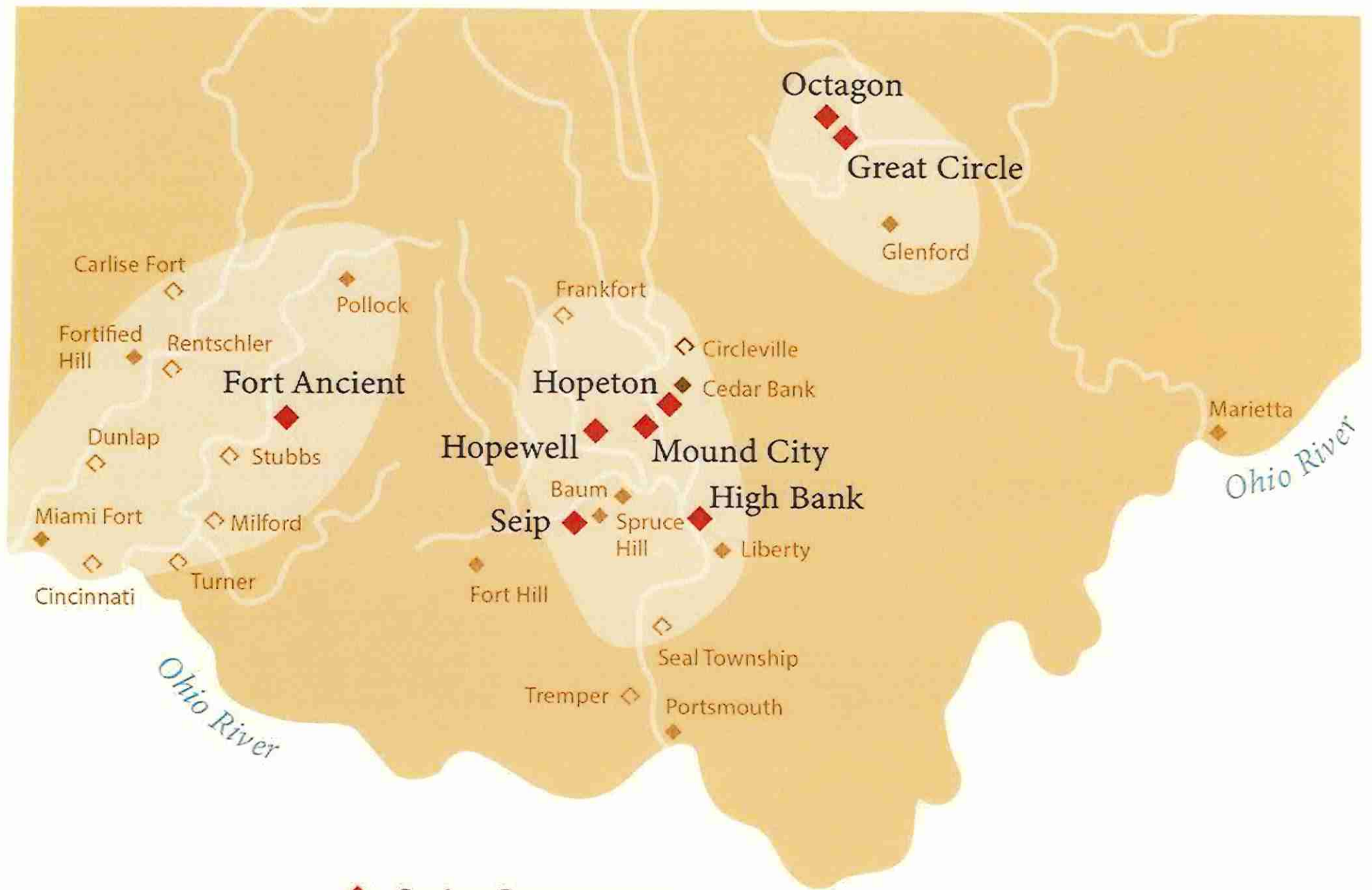

- ◆ Series Components
- ◆ Comparative Sites
- ◇ Scant or No Remains

Hopewell Architecture:

Geometric Earthworks up to 2/3 mile across, concentrated in southern Ohio



High Bank Works, Ross County



Newark Octagon, Licking County

Ohio's Hopewell Earthworks and UNESCO World Heritage

WORLD
HERITAGE
OHIO

Hopewell Site

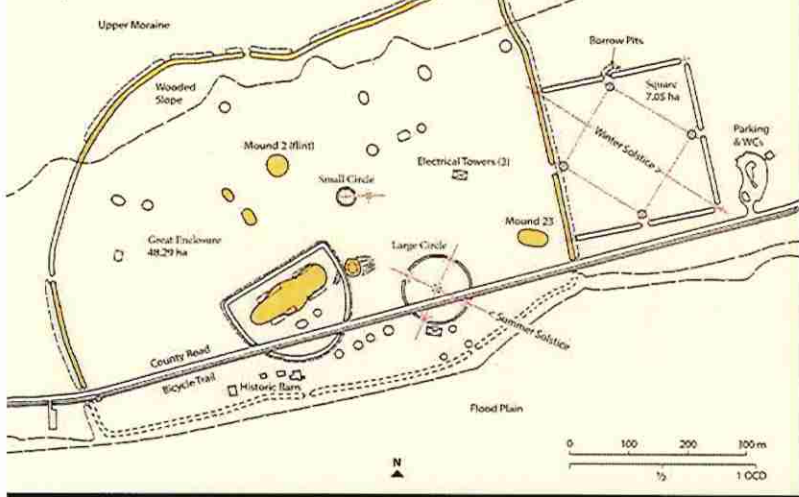

Hopeton

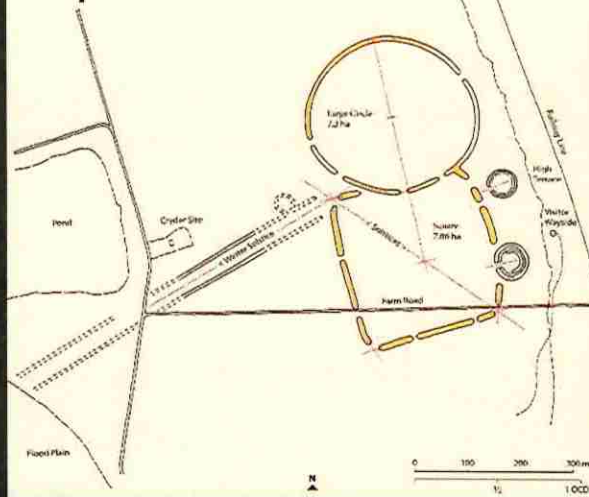

Mound City

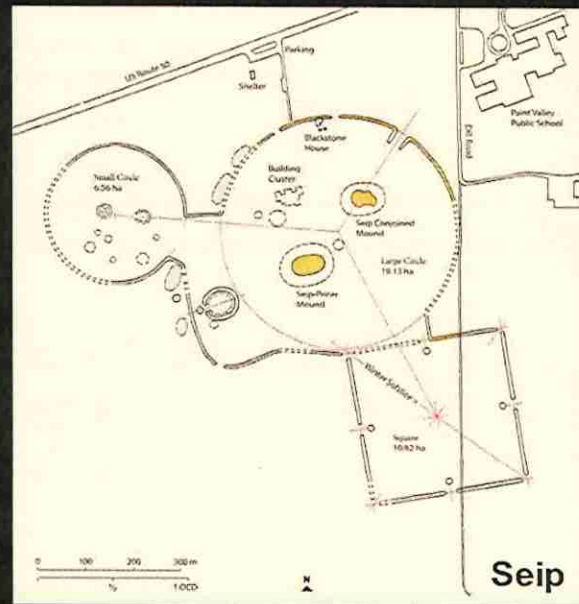
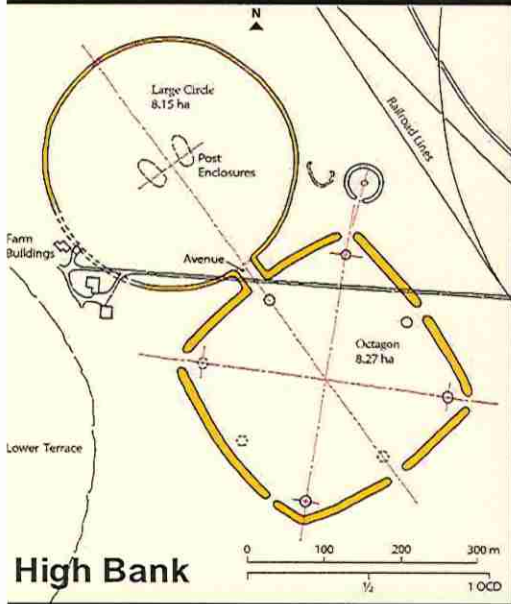
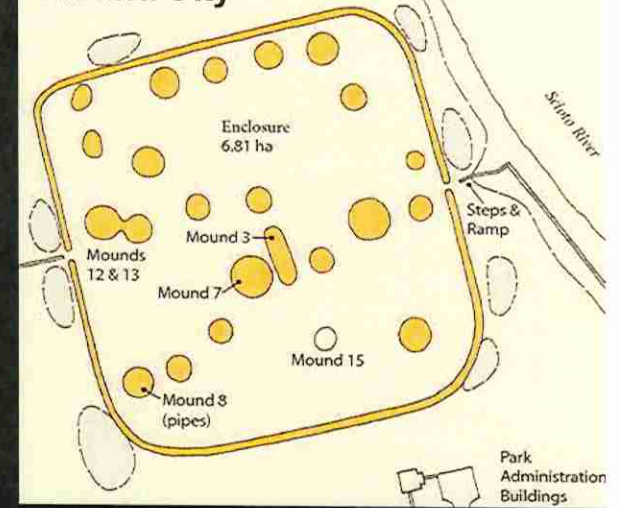

Newark Octagon

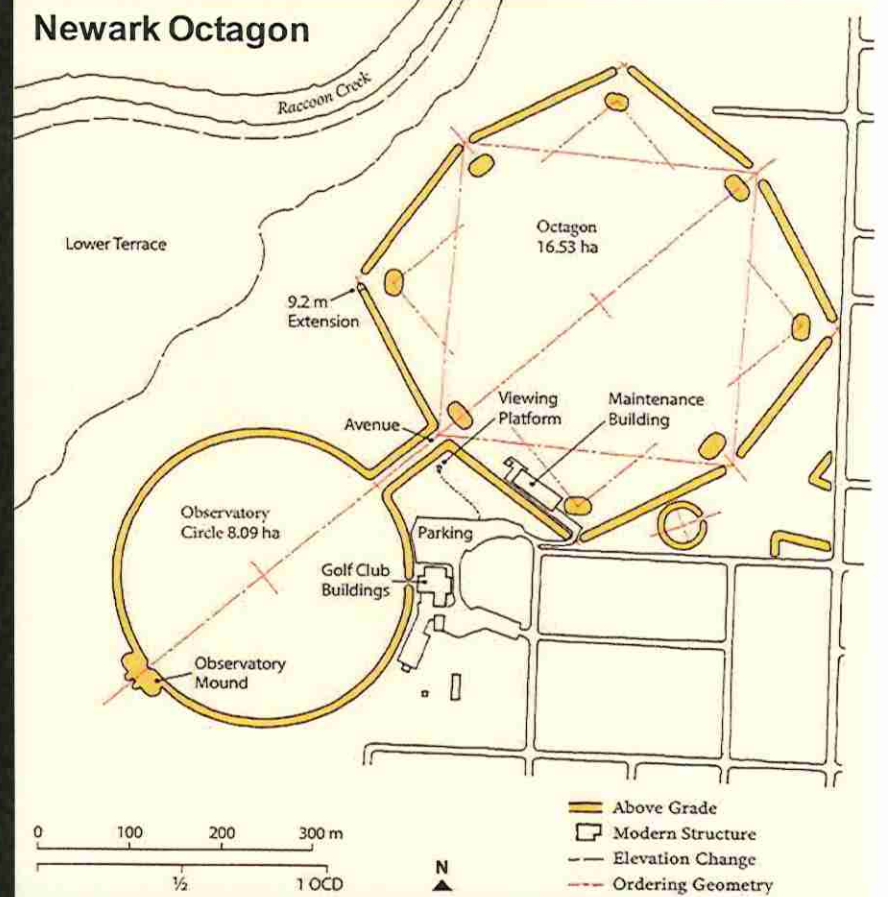

GEOMETRIC ENCLOSURES



GEOMETRY

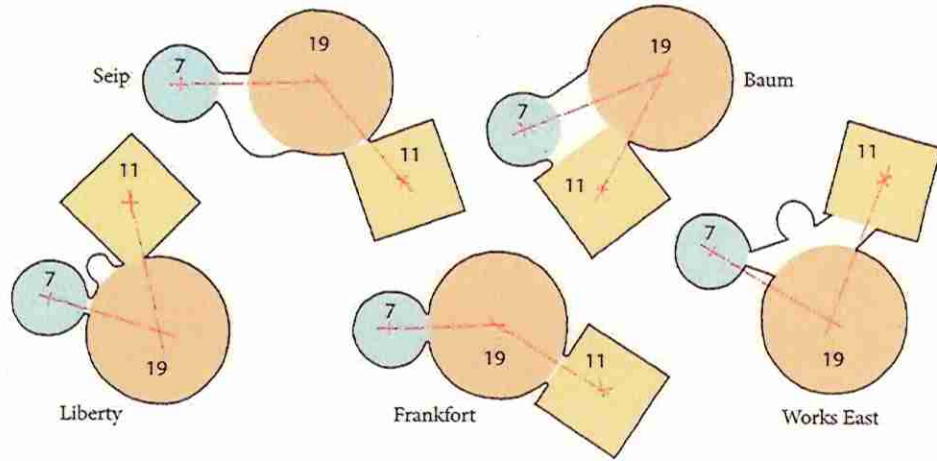

Consistent distances from centerpoints

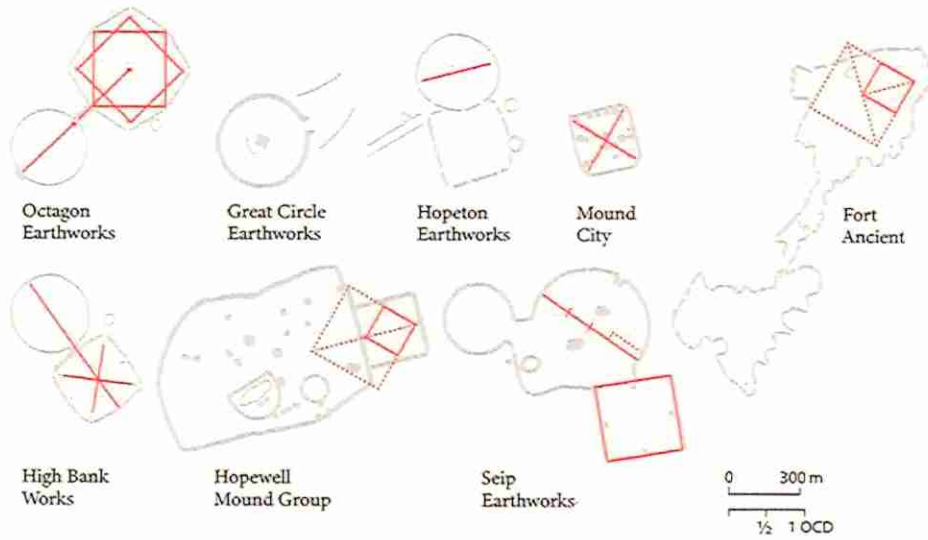

Consistent derivations of the same unit (OCD)

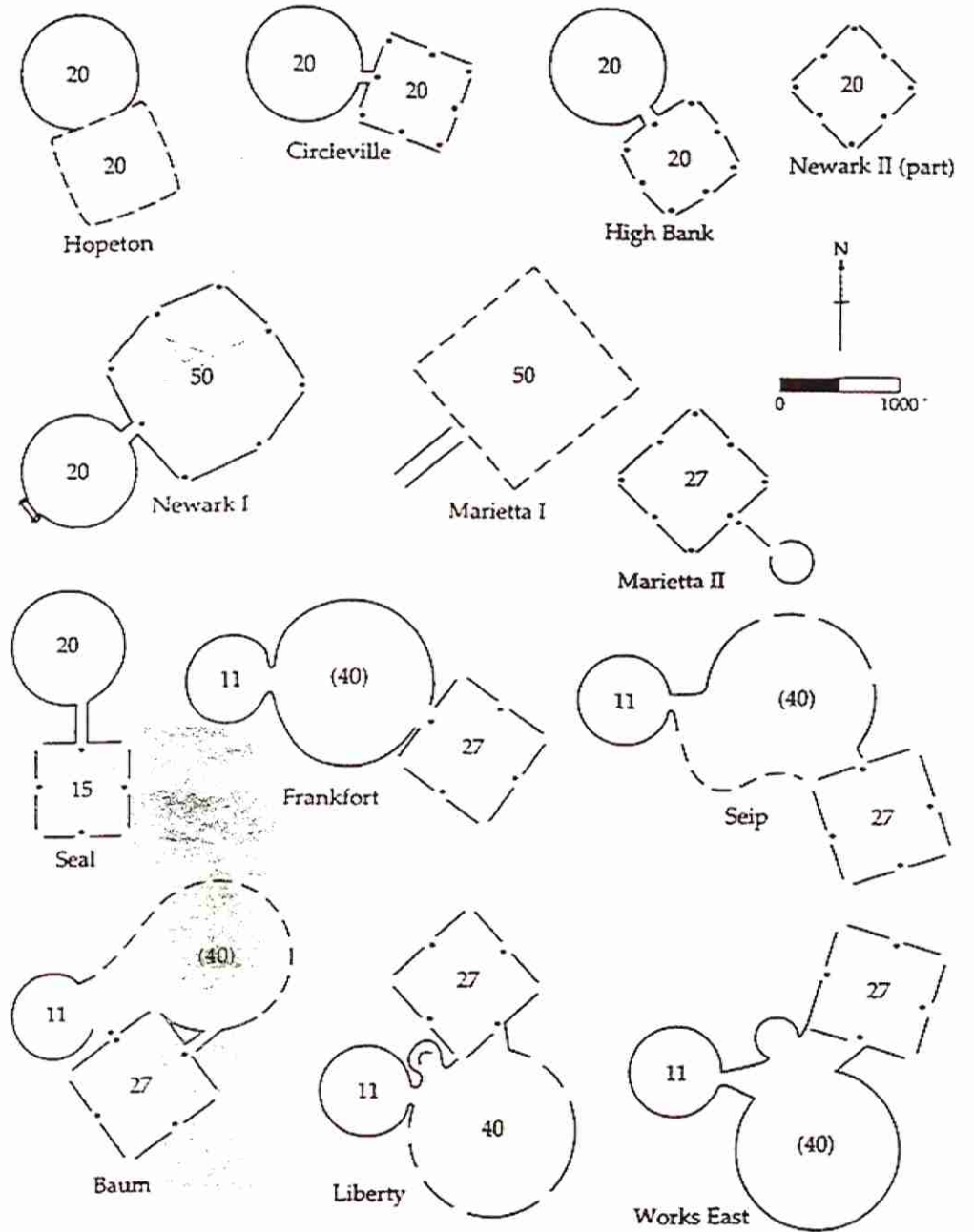

Consistent areas of enclosed acreage

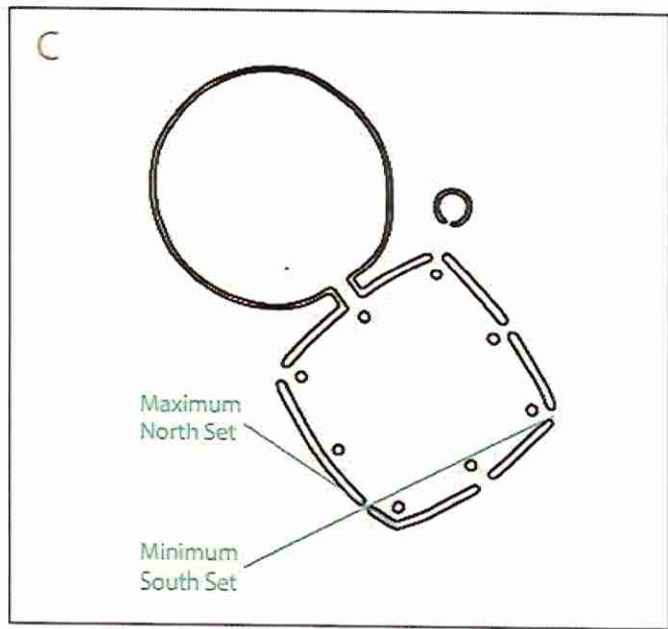
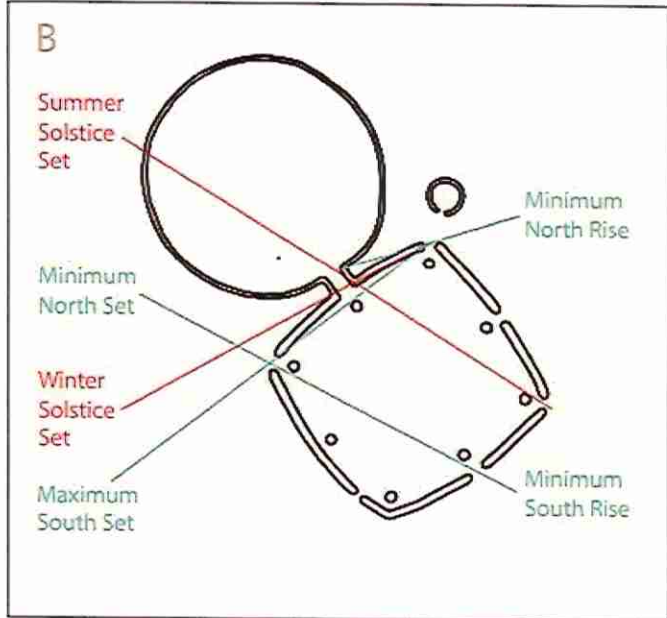
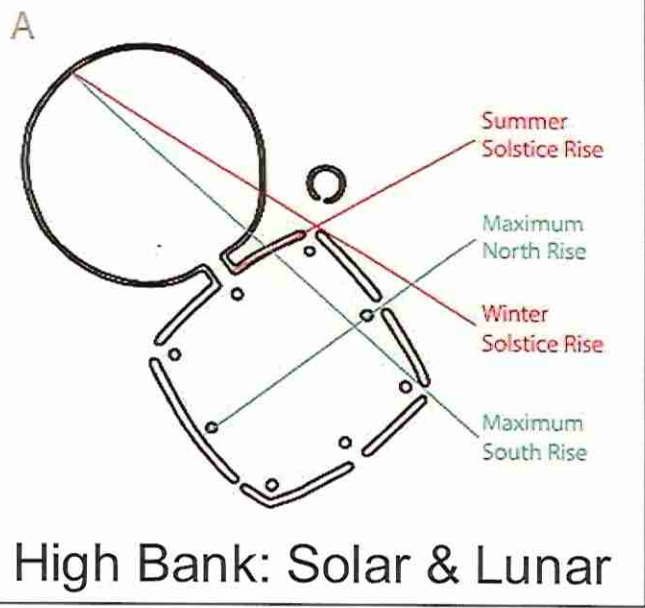

High Bank: Solar & Lunar

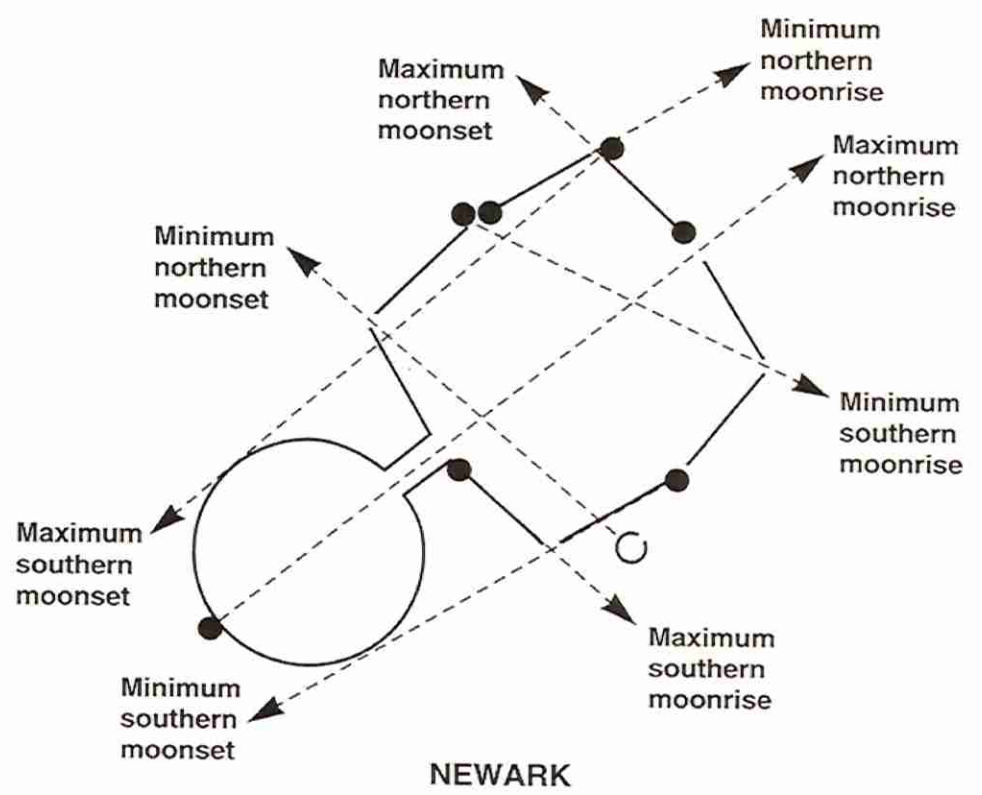

Newark: Lunar

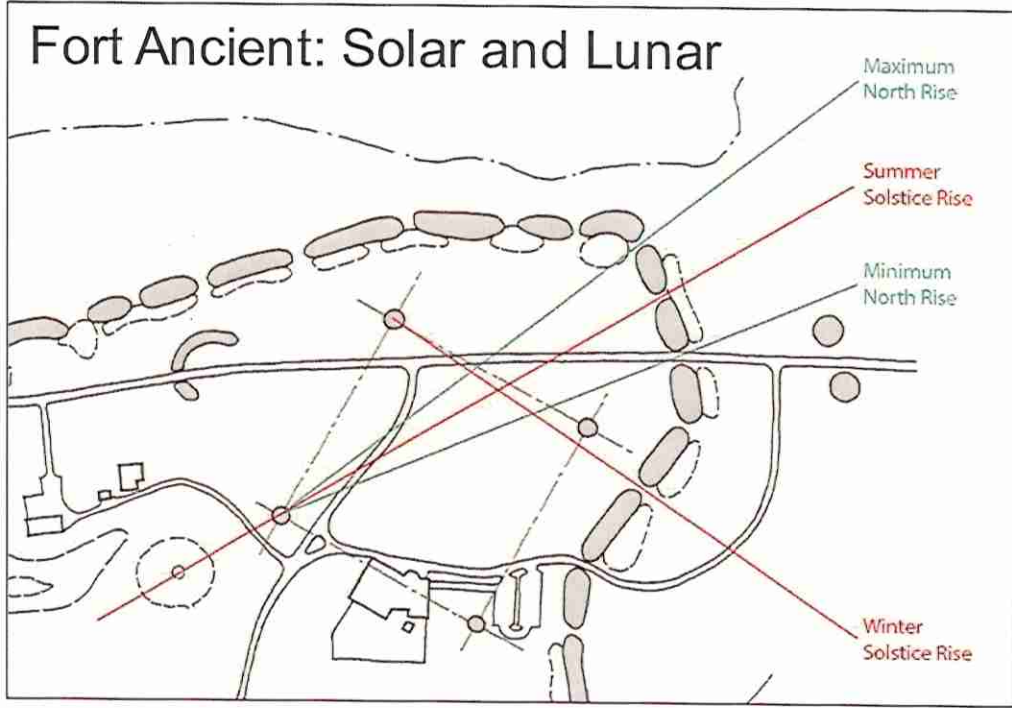

ASTRONOMICAL ALIGNMENTS



Maximum Northern Moonrise at Newark Octagon

... and Hilltop Enclosures, up to 125 acres.



Fort Ancient, Warren County

Ohio's Hopewell Earthworks and UNESCO World Heritage

WORLD
HERITAGE
OHIO

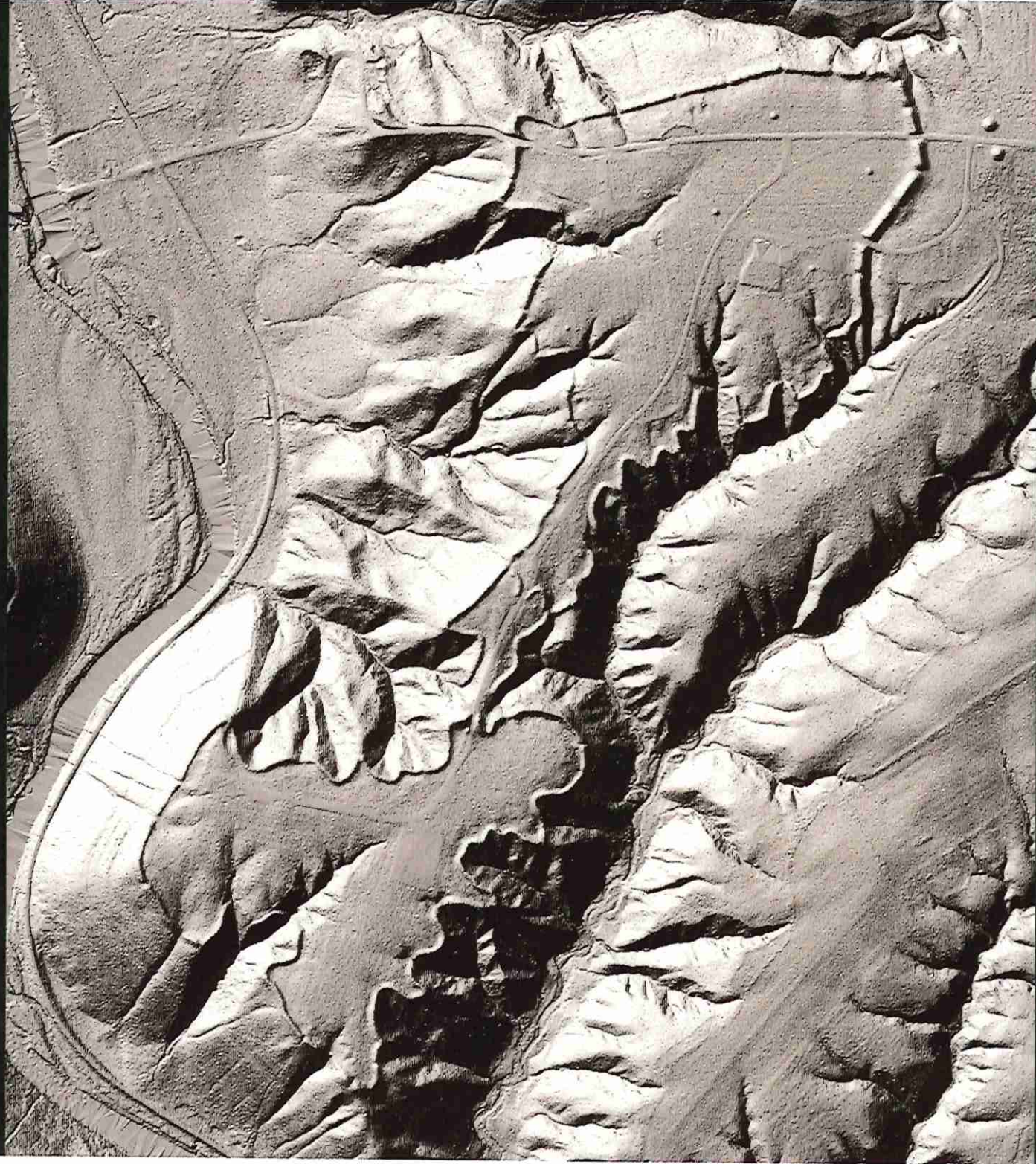

Fort Ancient



Fort Ancient



Fort Ancient



Fort Ancient

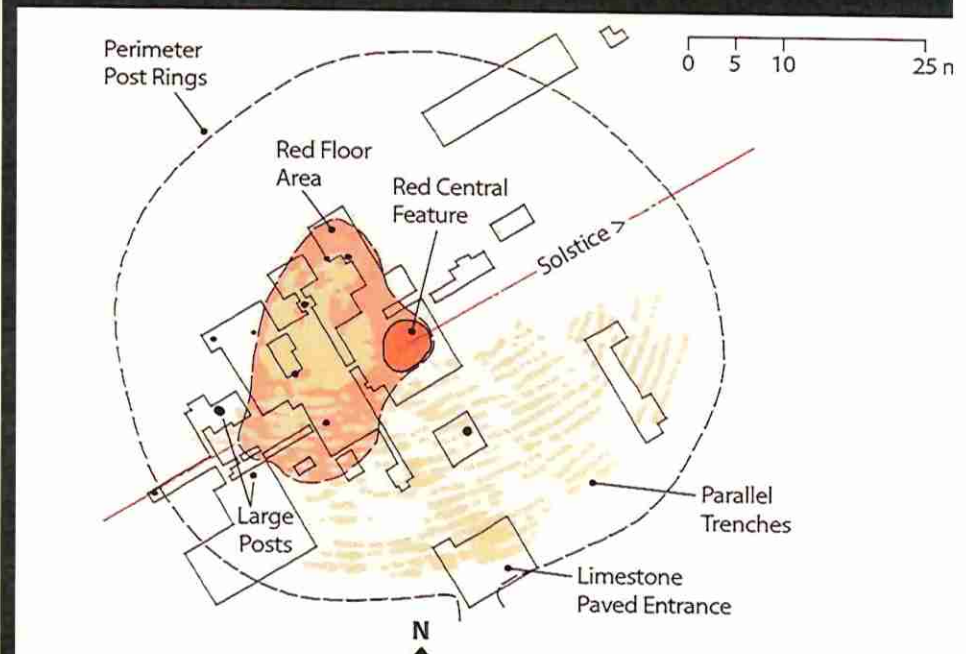
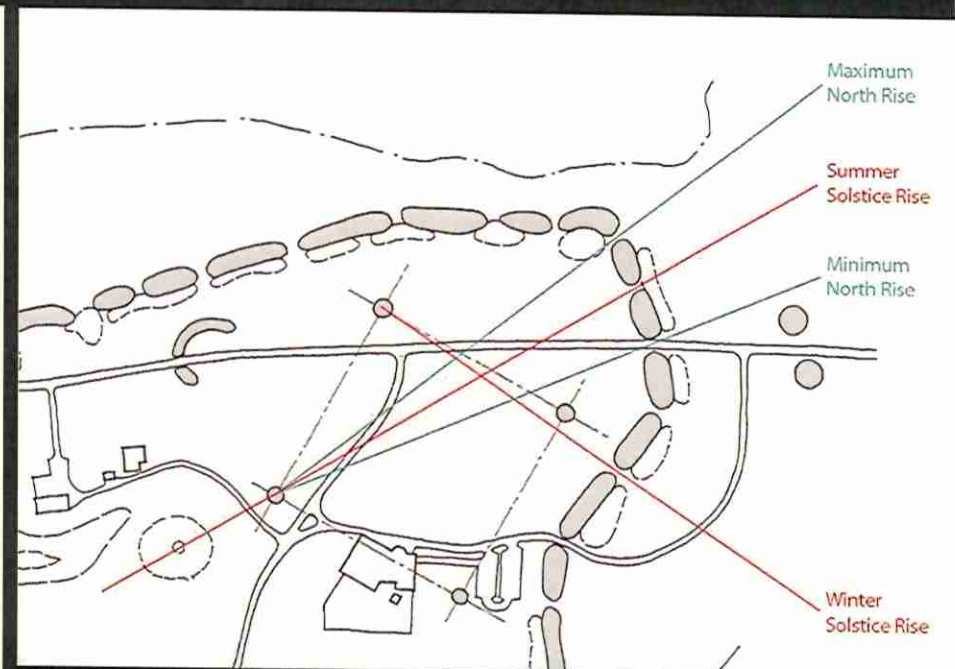
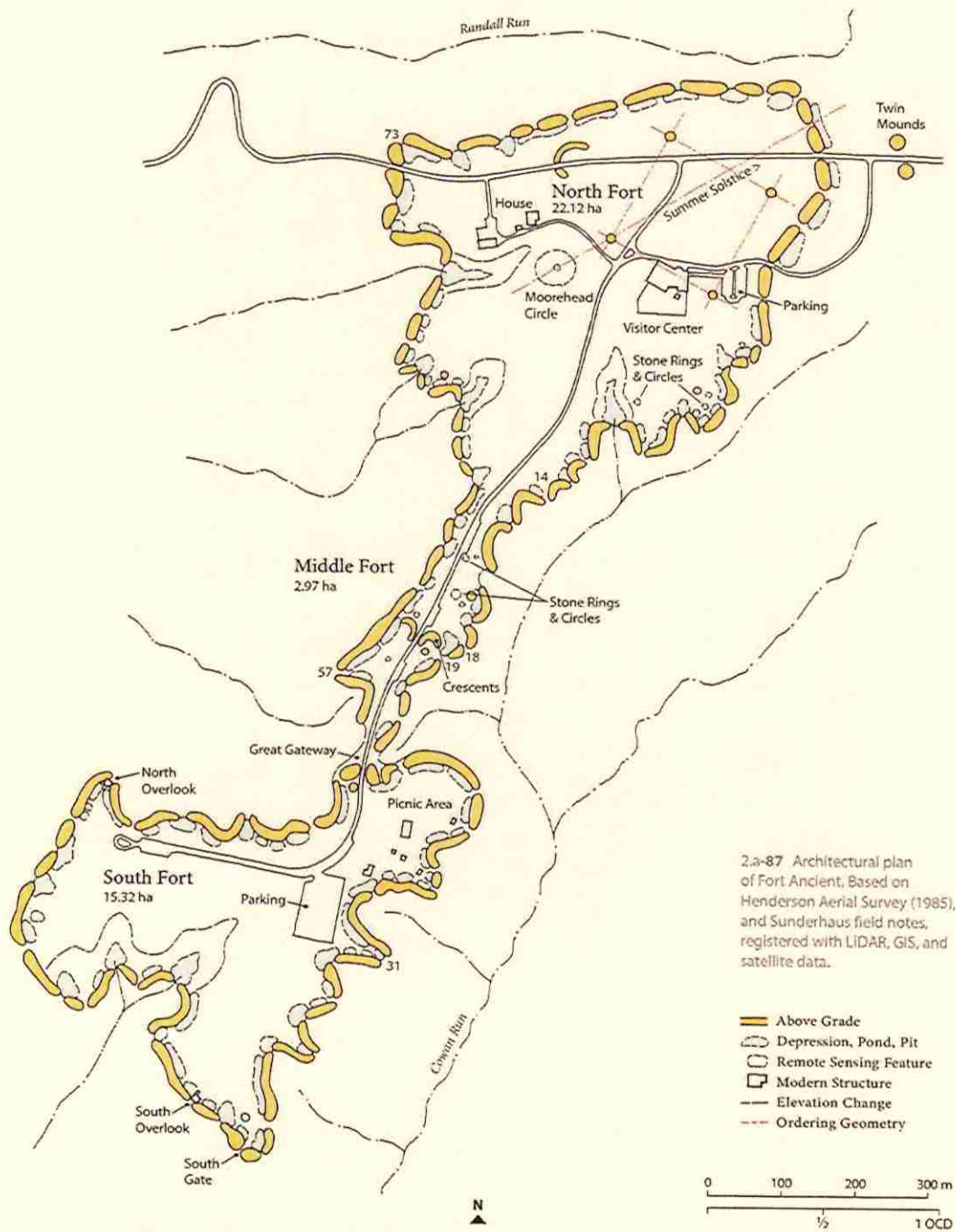

Moorehead Circle and astronomical alignments at Fort Ancient





Proclamation

*From the Office of the Board of County Commissioners
Warren County, Ohio*

**HONOR AND RECOGNIZE FORT ANCIENT EARTHWORKS AS AN
"UNESCO WORLD HERITAGE SITE"**

WHEREAS, Fort Ancient was built on a steep bluff overlooking the Little Miami River in Warren County and has become a nature-lover's dream with miles of trails and embankments reaching 23 feet high; and

WHEREAS, Fort Ancient also provides a museum offering over 9,000 square feet of exhibition space for tourists to learn about the Hopewell and Fort Ancient cultures; and

WHEREAS, Ohio's oldest state park and the largest hilltop enclosure in North America, built around 2,000 years by what is now referred to as the Hopewell Culture; and

WHEREAS, in 1966 Fort Ancient became nationally recognized when it was named a National Historic Landmark; and

WHEREAS, in April 1981 the state legislature authorized the Ohio Archaeological and Historical Society (now the Ohio History Connection) to care for the site, becoming Ohio's first state park, and

WHEREAS, on September 19, 2023 the UNESCO World Heritage Committee inscribed Ohio's eight Hopewell Ceremonial Earthworks, including Fort Ancient Earthworks and the United States' 25th addition to the World Heritage List; and

NOW THEREFORE BE IT RESOLVED, to recognize and honor Fort Ancient Earthworks and the Ohio History Connection for becoming Ohio's first UNESCO World Heritage site.

*IN WITNESS WHEREOF, we hereunto subscribed
Our names and caused the seal of Warren County to
be affixed at Lebanon this 5th day of December, in the
Year of our Lord, Two Thousand Twenty- Three.*

BOARD OF COUNTY COMMISSIONERS

Shannon Jones, President

David G. Young

Tom Grossmann

APPROVE ANNEXATION OF 0.8143 ACRES TO THE CITY OF SOUTH LEBANON, RICHARD PAOLO, AGENT, PURSUANT TO OHIO REVISED CODE SECTION 709.023 [A.K.A. EXPEDITED TYPE 2 ANNEXATION]

WHEREAS, this Board is in receipt of an annexation petition from Richard Paolo, Agent to annex 0.8143 acres (Striker Road Annexation) to the City of South Lebanon filed on the 21st day of November 2023; and

WHEREAS, said petition for annexation was filed pursuant to and specifically requests that the Board follow ORC §709.023 [a.k.a. Expedited Type 2 Annexation]; and,

WHEREAS, said petition has been determined to contain the following matters required by law:

- The petition meets all the requirements set for in, and was filed in the manner provided in, ORC 709.021, ORC 709.023(E)(1)
- The person who signed the petition are owners of property located in the territory proposed to be annexed, and they constitute all owners in the territory, ORC 709.023 (E)(2)
- The territory proposed to be annexed does not exceed 500 acres, ORC 709.023 (E)(3)
- The territory proposed to be annexed shares a contiguous boundary with the municipality for a continuous length of at least 5% of the perimeter of the territory proposed to be annexed, ORC 709.023 (E)(4)
- The annexation will not create an unincorporated area of the township that is surrounded by the territory proposed to be annexed, ORC 709.023 (E)(5)
- The municipality has agreed to provide the territory proposed to be annexed the services specified in the municipal services statement, ORC 709.023 (E)(6)
- If a street or highway will be divided or segmented by the boundary line between the municipality and township as to create a road maintenance problem, the municipality has agreed as a condition of annexation to assume maintenance of that street or highway or to otherwise correct the problem. (ORC 709.023 (E) (7))

NOW THEREFORE BE IT RESOLVED, that the prayer of said petition be approved.

M moved for adoption of the foregoing resolution, being seconded by M. Upon call of the roll, the following vote resulted:

M
M
M

Resolution adopted this 5th day of November 2023.

BOARD OF COUNTY COMMISSIONERS

Tina Osborne, Clerk

cc: Richard Paolo, Agent
RZC
Auditor _____
City of South Lebanon

RPC
Map Room
Annexation file
Hamilton Township

Final Report
 WARREN COUNTY ENGINEERS OFFICE
 TAX MAP DEPARTMENT
 ANNEXATION REVIEW REPORT
 (In Accordance with O.R.C. 709.031)
 "EXHIBIT F"

Annexation to: South Lebanon

Date Filed: 11/6/2023

Filed by: Tina Donnelly

Total Acreage: 0.8459

I. MAP CONTENTS

- | | | | |
|---|--------------------------------------|----|--------------------------------------|
| a) Section-Town-Range, or Military Survey, County, and State | <input checked="" type="radio"/> YES | NO | N/A |
| b) Boundary of Territory proposed for annexation to be in bold lines for ease in identification | <input checked="" type="radio"/> YES | NO | N/A |
| c) Lengths and bearings of the boundary of the territory. (May be obtained from county records) | <input checked="" type="radio"/> YES | NO | N/A |
| d) All roads and streets. | <input checked="" type="radio"/> YES | NO | N/A |
| e) All existing corporation lines. | <input checked="" type="radio"/> YES | NO | N/A |
| f) All section, quarter section or VMS lines correctly labeled. | YES | NO | <input checked="" type="radio"/> N/A |
| g) All property lines. | <input checked="" type="radio"/> YES | NO | N/A |
| h) Names of all allotments within the territory with plat book and page as recorded in the County plat records. | <input checked="" type="radio"/> YES | NO | N/A |
| i) Lot numbers on plotted property. | <input checked="" type="radio"/> YES | NO | N/A |
| j) On unplotted property, the names of owners and deed reference with the acreage and dimensions. | <input checked="" type="radio"/> YES | NO | N/A |
| k) Annexation must be contiguous to 5% of existing corp. line <u>~44.02%</u> | <input checked="" type="radio"/> YES | NO | N/A |

II. LEGEND CONTENTS

- | | | | |
|---|--------------------------------------|----|-----|
| a) Formal identification of territory | <input checked="" type="radio"/> YES | NO | N/A |
| b) Total acreage in annexation territory with acreage breakdown of each individual parcel. | <input checked="" type="radio"/> YES | NO | N/A |
| c) Lengths of each road in territory | <input checked="" type="radio"/> YES | NO | N/A |
| d) North arrow | <input checked="" type="radio"/> YES | NO | N/A |
| e) Scale of map | <input checked="" type="radio"/> YES | NO | N/A |
| f) Date and name of surveyor with certification, preparer of map shall state if map and description are prepared by new survey or if prepared by existing deeds and plats of records. | <input checked="" type="radio"/> YES | NO | N/A |
| g) Vicinity map to designate location of annexation. | <input checked="" type="radio"/> YES | NO | N/A |

III. OTHER REQUIREMENTS

- | | | | |
|---|--------------------------------------|----|-----|
| a) Map on 24" x 36" mylar or linen reproducible | <input checked="" type="radio"/> YES | NO | N/A |
| b) Accurate map | <input checked="" type="radio"/> YES | NO | N/A |
| c) Description accurate and in accordance with plat | <input checked="" type="radio"/> YES | NO | N/A |
| d) Number of property owners in territory | <input checked="" type="radio"/> YES | NO | N/A |
| e) Number of property owners signing the petition | <input checked="" type="radio"/> YES | NO | N/A |
| f) Signature Block for Warren County Commissioners | <input checked="" type="radio"/> YES | NO | N/A |
| g) Signature Block for City or Village Officials | <input checked="" type="radio"/> YES | NO | N/A |
| h) Signature Block for Warren County Auditor | <input checked="" type="radio"/> YES | NO | N/A |
| i) Signature Block for Warren County Recorder | <input checked="" type="radio"/> YES | NO | N/A |
| j) List parcels within and adjacent to annexation area. Include names, addresses and parcel numbers. This list should be contained in the petition. | <input checked="" type="radio"/> YES | NO | N/A |

Engineer's Office Comments: _____

Reviewed by: Balinda Sheppard Date: 11/7/2023

 Neil F. Tunison P.E., P.S.
 Warren County Engineer

**PETITION FOR ANNEXATION OF
CERTAIN TERRITORY INTO THE CITY OF SOUTH LEBANON**

November 6, 2023

TO: The Commissioners of Warren County, Ohio:

RECEIVED
2023 NOV -6 PM 1:15

The undersigned being all of the owners of the real estate in the territory located in the County of Warren, Hamilton Township and adjacent to the City of South Lebanon, as such territory is described upon "Exhibit A" attached hereto and made a part hereof, hereby petition for annexation of this territory to the City of South Lebanon, Ohio, all in accordance with Ohio Revised Code Section 709.023, to-wit:

See "Exhibit A" for territory to be annexed, commonly known as the "Striker Road Annexation".

The territory to be annexed is further delineated upon the Plat attached hereto marked as "Exhibit B" and by reference incorporated herein.

Richard A. Paolo or Tina M. Donnelly, Attorneys at Law, 2200 U.S. Bank Tower, 425 Walnut Street, Cincinnati, Ohio 45202, either one of them acting alone, is hereby appointed agent for the undersigned Petitioners in accordance with Ohio Revised Code Section 709.02. Said agent is hereby authorized to make any amendment or deletion to the within Petition, legal description, and Plat which, in his or her absolute and complete discretion, he or she deems necessary or proper under the circumstances then existing and, in particular, to make any amendments in order to correct any discrepancy or mistake noted by the County Engineer in his examination of the Petition, legal description, or Plat.

NOTICE TO PETITIONERS. Your signature below is important and requests annexation of your property to the City of South Lebanon.

WHOEVER SIGNS THIS PETITION EXPRESSLY WAIVES THEIR RIGHT TO APPEAL IN LAW OR EQUITY FROM THE BOARD OF COUNTY COMMISSIONERS' ENTRY OF ANY RESOLUTION PERTAINING TO THIS SPECIAL ANNEXATION PROCEDURE, ALTHOUGH A WRIT OF MANDAMUS MAY BE SOUGHT TO COMPEL THE BOARD TO PERFORM ITS DUTIES REQUIRED BY LAW FOR THIS SPECIAL ANNEXATION PROCEDURE.

NAME/MAILING ADDRESS	ADDRESS OF PROPERTY	LOT NO. OR ACREAGE	AUDITOR'S PARCEL #
Beaver Creek Site Management, LLC 2718 Ridgewood Ave Cincinnati, OH 45213	Striker Road Maineville, OH 45039	Lot 1	16-11-295-017
		Lot 2	16-11-295-018

TOTAL ACREAGE TO BE ANNEXED: 0.8143 Acres per Annexation Plat

EXCLUSIVE OF RIGHT OF WAY: 0.3016 Acres in Right-of-Way

**SIGNATURE PAGE
TO PETITION FOR ANNEXATION OF
CERTAIN TERRITORY INTO THE CITY OF SOUTH LEBANON**

Beaver Creek Site Management, LLC

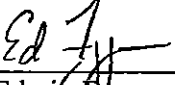
By: 

Edwin Farruggia, Managing Member

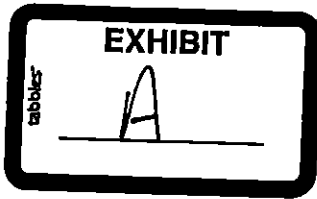

DESCRIPTION FOR:

**CITY of SOUTH LEBANON
ANNEXATION**

LOCATION:

**"STRIKER ROAD AREA"
0.8459 Acres**

Situate in Military Survey Number 1548, Hamilton Township, Warren County, Ohio and including all of Lots 1 and 2 of the Striker Road Plat recorded in Plat Book 91, Pages 43-44 (all records of the Warren County, Ohio Recorder's Office) as conveyed to Beaver Creek Site Management, LLC by deed recorded in Document Number 2023-016021 and also including 0.0316 ac. of right-of-way dedicated to the Warren County Commissioners on said plat and being more particularly described as follows:

Beginning at the northeast corner of said Lot 2 in the existing corporation line of the City of South Lebanon and west line of the original 77 acre (64.25 acre net) tract as conveyed to Terry L. Irwin, Trustee and Lea F. Irwin, Trustee of the Irwin Family Living Trust dated July 18, 2016 by deed recorded in Document Number 2018-029037;

Thence with said corporation line, along the west line of said Irwin tract, South $01^{\circ}04'16''$ East, 536.80 feet to the north line of Lot 30 Open Space of Willow Grove recorded in Plat Book 51, Pages 94-95 as conveyed to Heartland, Ltd., LLC by deed recorded in Official Record 1976, Page 830;

Thence, along the north line of said Lot 30 Open Space, South $88^{\circ}53'59''$ West, 116.31 feet to an east line of Striker Road (R/W Varies) as shown on the aforesaid Striker Road Plat;

Thence in part along east lines of said Striker Road, with the west line of aforesaid Lot 1 and extension thereof, crossing said right-of-way of Striker Road and with the west line of aforesaid Lot 2, North $08^{\circ}59'56''$ East, 545.43 feet to the northwest corner of said Lot 2;

Thence continuing along said right-of-way of Striker Road, with the north line of said Lot 2, North $88^{\circ}55'44''$ East, 20.97 feet to the point of beginning.

Containing 0.8459 acres of land, more or less.

Subject to all legal highways, easements and restrictions of record.

The above description is the result of a Plat of Annexation by McGill Smith Punshon, Inc. under the direction of Richard D. Nichols, P.S. No. 7929, dated the 14th of July 2023. The bearings in the above description are based on the subject property record plat recorded in Plat Book 91, Pages 43-44, records of the Warren County, Ohio Recorder's Office.

Prepared by: McGill Smith Punshon, Inc.

Date: 31 AUG 2023

MSP No.: 16448.02

16448023-LEG-ANX-00

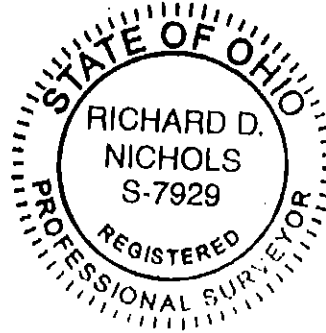

Robert Dill
10/30/23



COUNTY COMMISSIONERS:
 WE, THE BOARD OF COUNTY COMMISSIONERS OF WARREN COUNTY, OHIO DO HEREBY APPROVE THIS PLAT ON THIS _____ DAY OF _____, 2023.

CITY APPROVAL:
 CITY OF SOUTH LEBANON CLERK _____ DATE _____

COUNTY RECORDER:
 FILE NO. _____ RECEIVED THIS _____ DAY OF _____, 2023, AT _____ A.M. P.M. RECORDED THIS _____ DAY OF _____, 2023, AT _____ A.M. P.M. RECORDED IN PLAT BOOK NO. _____ PAGE _____ FEET _____ BY _____ WARREN COUNTY RECORDER

COUNTY AUDITOR:
 TRANSMITTED THIS _____ DAY OF _____, 2023, BY _____ WARREN COUNTY AUDITOR

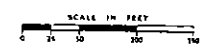

PRO. 16-11-2023-01
 17974. Name: STRIKER ROAD
 1514' Name: PLOT 1514' Name: PLOT 1514' Name: PLOT 1514'
 GENERAL OF PL. PLOT 1514'
 NAME & COUNTY TO PL. PLOT 1514', PL. PLOT 1514', PL. PLOT 1514', PL. PLOT 1514'
 NAME: STRIKER

EX. CITY OF SOUTH LEBANON CORP.
 AREA TO BE ANNEXED TO THE CITY OF SOUTH LEBANON

TOTAL AREA IN PROPOSED ANNEXATION:
0.8459 ACRES ±

ACREAGE BREAKDOWN (BASED ON RECORDS AND SHOULD BE CONSIDERED APPROXIMATE):

PARCEL	OWNER	DEED REFERENCE	ACRES
16-11-295-017	BEAVER CREEK SITE MANAGEMENT, LLC	DOC. NO. 2023-014022	0.4790 AC. (LOT 1- STRIKER ROAD PLAT, P.B. 91, PP. 43-44)
16-11-295-018	BEAVER CREEK SITE MANAGEMENT, LLC	DOC. NO. 2023-014022	0.3253 AC. (LOT 2- STRIKER ROAD PLAT, P.B. 91, PP. 43-44)
			0.8043 AC. (PART OF DEDICATED R/W IN P.B. 91, PP. 43-44)
			0.0416 AC. TOTAL

PERIMETER OF PROPOSED ANNEXATION AREA: 1729.51 FEET CONTIGUOUS, CONTIGUOUS BOUNDARY WITH CITY OF SOUTH LEBANON: 136.50 FEET CONTIGUITY WITH CITY OF SOUTH LEBANON: 64.07 %

BOUNDARIES SHOWN ON THIS PLAT ARE BASED ON THE SURVEY RECORDS OF THE WARREN COUNTY, OHIO RECORDS OFFICE. THESE BOUNDARIES ARE NOT TO BE USED AS A BASIS FOR ANY OTHER PURPOSES WITHOUT THE WRITTEN CONSENT OF THE SURVEYOR.

**PLAT OF ANNEXATION
 CITY OF SOUTH LEBANON
 "STRIKER ROAD AREA"**
 MILITARY SURVEY NUMBER 1548
 HAMILTON TOWNSHIP, WARREN COUNTY, OHIO

Date: 16 JUL 2023
 Scale: 1" = 50'
 County: Warren
 Project Number: 16458-23
 File No: 1/1

MSP DESIGN
 McMill Smith Punshan

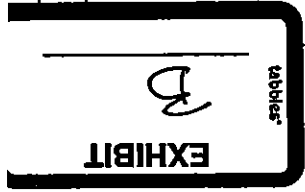
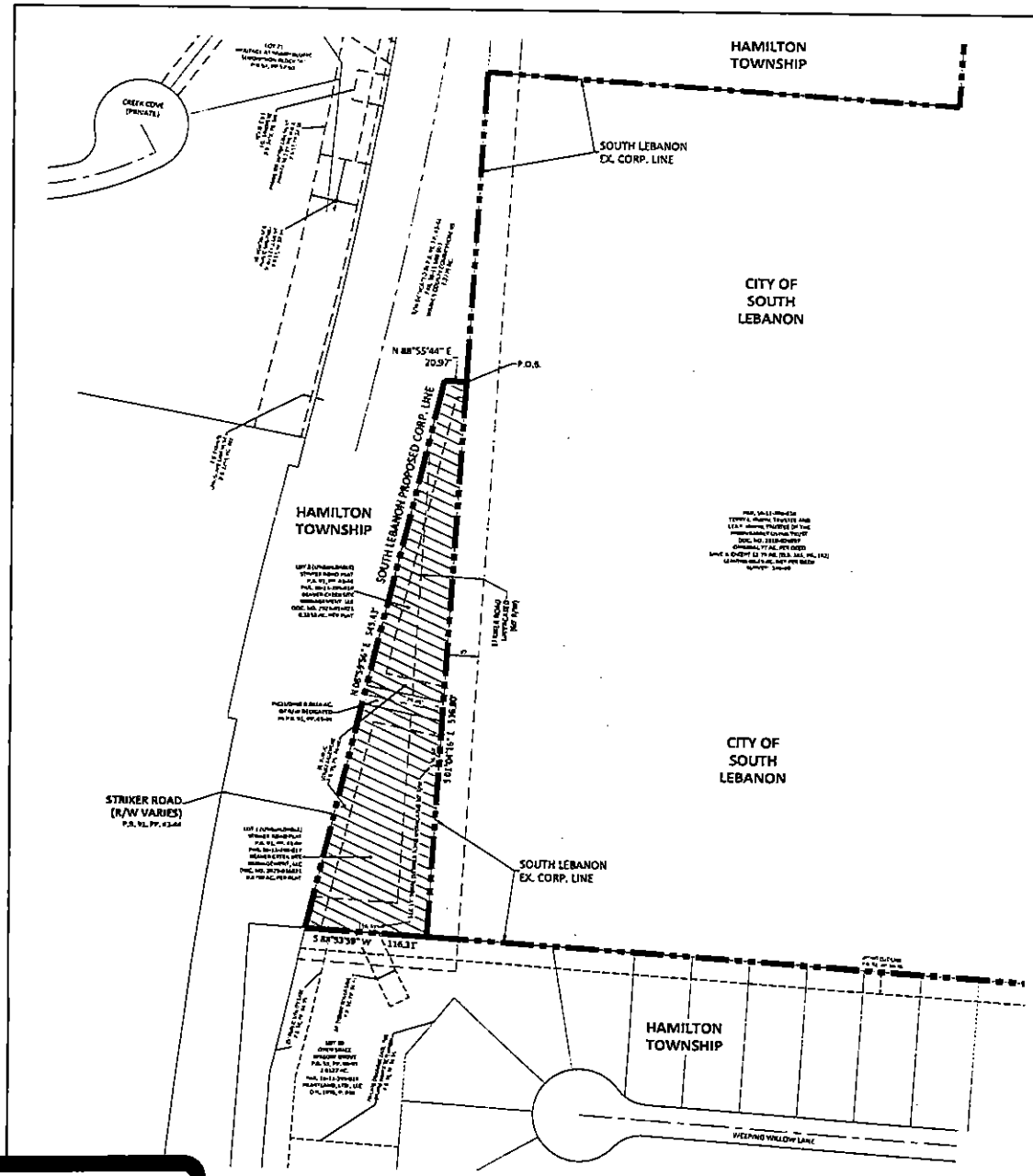

**STATEMENT BY AGENT OF TERRITORY SOUGHT TO BE ANNEXED
TO THE CITY OF HARRISON, OHIO**

POPULAR NAME OF TERRITORY: **Striker Road Annexation**
0.8143 Acres, Warren, Ohio

AGENT'S NAME: Richard A. Paolo, Esq.

ADDRESS: 2200 U.S. Bank Tower
425 Walnut Street
Cincinnati, Ohio 45202-3954
(513) 241-0400

PETITIONER'S NAME	MAILING ADDRESS	PERMANENT PARCEL NO.	PETITION SIGNED
Beavercreek Site Management, LLC	2718 Ridgewood Ave. Cincinnati, Ohio 45213	16-11-295-017 & 16-11-295-018	Yes

1. Number of owners of real estate in territory 1
2. Number of owners of real estate signing petition 1
3. Percent of signatures to total number of owners
 of real estate 100%

IN RE: PETITION FOR THE STRIKER ROAD ANNEXATION

Listing of all parcels in territory proposed for all annexation:

PETITIONER'S NAME	MAILING ADDRESS	PARCEL NO.
Beavercreek Site Management, LLC	2718 Ridgewood Ave. Cincinnati, Ohio 45213	16-11-295-017 & 16-11-295-018

Listing of parcels located adjacent to the territory (or directly across from it when road is adjacent to territory, proposed for annexation):

ADJACENT OWNER'S NAMES	MAILING ADDRESS	PARCEL NO.
Terry L. and Lea F. Irwin, Trustees of the Irwin Family Living Trust	P.O. Box 109 Kanab, UT 84741	16-11-200-010
Heartland LTD. LLC	1030 West Foster-Maineville Rd. Maineville, Ohio 45039	16-11-295-016
Warren County Commissioners, Etal c/o Miami Striker, LLC	P.O. Box 498007 Cincinnati, Ohio 45249	16-11-600-003

AFFIDAVIT OF SERVICE OF AGENT

**IN RE: PETITION FOR ANNEXATION OF THE
STRICKER ROAD ANNEXATION**

STATE OF OHIO)
)
COUNTY OF WARREN)

SS:

Tina M. Donnelly, Agent for Petitioners, being first duly cautioned and sworn, deposes that a copy of the attached Petition for Annexation of Territory to the City of South Lebanon, Warren County, Ohio, together with all exhibits thereto, at the time of filing the Petition with Warren County, Ohio on 6th day of November 2023, was served by Hand Delivery upon:

Tina Williams, Fiscal Officer
City of South Lebanon
10 N. High Street
South Lebanon, OH 45065

and

Kurt Weber, Fiscal Officer
Hamilton Township
7780 South State Route 48
Hamilton Township, Ohio 45039

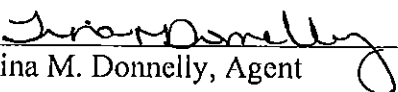
Tina M. Donnelly, Agent

Sworn to before me and subscribed in my presence this 6th day of November 2023, by Tina M. Donnelly, Agent for Petitioners.



TASHA CARNES
Notary Public, State of Ohio
My Commission Expires 04-08-2024

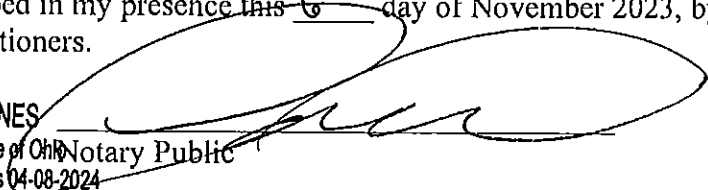

AFFIDAVIT OF SERVICE OF AGENT

**IN RE: PETITION FOR ANNEXATION OF THE
STRICKER ROAD ANNEXATION**

STATE OF OHIO)
) SS:
COUNTY OF HAMILTON)

Tina M. Donnelly, Agent for Petitioners, being first duly cautioned and sworn, deposes that a copy of the attached Petition for Annexation of Territory was served on the parcel Owners adjoining the property proposed for annexation, together with all exhibits thereto, within five days from the date of filing the Petition, on November 6th, 2023, by Regular Mail as listed in the attached Exhibit "A".

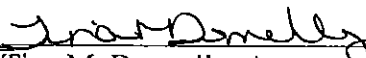
Tina M. Donnelly, Agent

Sworn to before me and subscribed in my presence this 6th day of November 2023, by Tina M Donnelly, Agent for Petitioners.



TASHA CARNES Notary Public
Notary Public, State of Ohio
My Commission Expires 04-08-2024

RECEIVED

CITY OF SOUTH LEBANON, OHIO 2023 NOV 21 AM 8:51
RESOLUTION NO. 2023-44

A RESOLUTION INDICATING THE MUNICIPAL SERVICES TO BE PROVIDED TO .8143+/- ACRES OF REAL PROPERTY PROPOSED TO BE ANNEXED TO THE CITY OF SOUTH LEBANON, OHIO, FROM HAMILTON TOWNSHIP, WARREN COUNTY, AND DECLARING AN EMERGENCY

WHEREAS, pursuant to R.C. 709.023, real estate consisting of .8143+/- acres of real property was identified in a petition for annexation ("Striker Property Annexation") filed with the Board of County Commissioners of Warren County, Ohio, on November 6, 2023, notice of such filing which, along with a copy of the petition, its attachments and documents accompanying the petition as filed, were duly served upon the City of South Lebanon as prescribed by law, and are on file with the City Clerk; and

WHEREAS, R.C. 709.023(C) and R.C. 709.023(E)(6) provide that the municipality to which any such land is proposed to be annexed shall indicate those services it will provide to such land and an approximate date by which it will provide them to the territory proposed for annexation upon annexation; and

WHEREAS, R.C. 709.023(C) requires council to adopt a resolution indicating such services within twenty (20) days after the date the petition is filed; and

WHEREAS, immediate action is required to assure this resolution is adopted and submitted to the Board of County Commissioners within the timeframe specified in the Ohio Revised Code, and such action is necessary in order to preserve the public peace, health, safety or welfare of the City.

NOW, THEREFORE, BE IT RESOLVED by the Council of the City of South Lebanon, Ohio, at least two-thirds of all members elected thereto concurring:

Section 1. In the event the above-referenced .8143+/- acres of real property known as the "Striker Property Annexation" are annexed to the City of South Lebanon from Hamilton Township, Warren County, Ohio, the City of South Lebanon will provide the entire annexed territory with the following services: police protection, snow and ice removal, zoning, a planning and zoning department with the full range of services, including review, permit, inspection and developmental services, and waste collection. These services shall be available and provided when the City of South Lebanon's resolution or ordinance accepting the annexation becomes final as provided by law. Services will be provided by the

City of South Lebanon to the annexation territory on the same terms and conditions and subject to the rates, rules and regulations established by City ordinances including the codified ordinances of the City of South Lebanon as they are provided to properties located within the City of South Lebanon. A copy of the map or plat and legal description of the annexation territory is attached to this Resolution.

Section 2. The Council of the City of South Lebanon supports the Striker Property Annexation.

Section 3. The Clerk is directed to provide a certified copy of this Resolution to the Board of County Commissioners of Warren County, Ohio for filing within 20 days after the filing of the petition for annexation.

Section 4. That the recitals contained within the Whereas Clauses set forth above are incorporated by reference herein.

Section 5. That this Resolution is hereby declared to be an emergency measure in accordance with Ohio Rev. Code § 731.30 for the immediate preservation of the public peace, health, safety and general welfare; and this Resolution shall be in full force and effective immediately upon its passage.

Section 6. That it is found and determined that all formal actions of the Council concerning and relating to the adoption of this Resolution were adopted in an open meeting of Council in compliance with all legal requirements, including Section 121.22 of the Ohio Revised Code.

Adopted this 16th day of November, 2023.

Attest: 
Petrina D. Williams, Director of Finance/Clerk

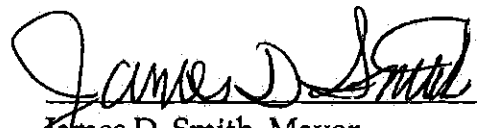
James D. Smith, Mayor

Rules Suspended: 11/14/2023 (if applicable)	Effective Date - 11/16/2023
Vote - <u>6</u> Yeas ___ Nays	
First Reading - / /2023	Effective Date - / /2023
Second Reading - / /2023	
Vote - ___ Yeas ___ Nays	

Prepared by and approved as to form:

ANDREW P. MEIER
LAW DIRECTOR
SOUTH LEBANON, OHIO

By: 
Date: 11/16/2023

CERTIFIED ORIGINAL

I, Tina Williams, CPA, Fiscal Officer of the City of South Lebanon, Ohio do hereby certify this to be the true and accurate copy of a document on file with my office

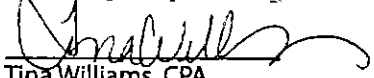
11/20/23 
Date Tina Williams, CPA
Fiscal Officer
City of South Lebanon, Ohio

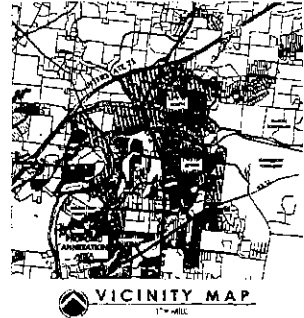
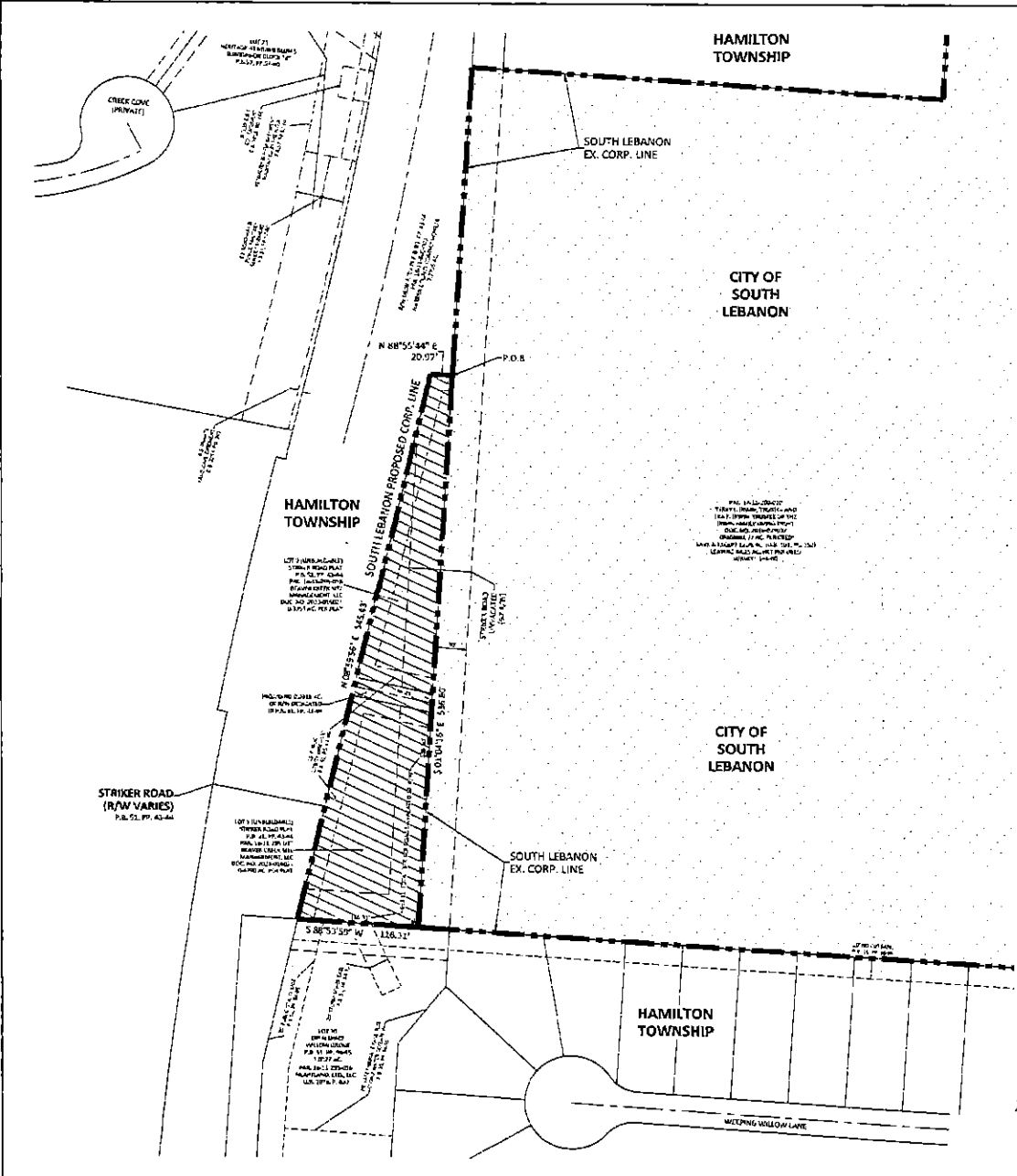

COUNTY COMMISSIONERS:
 BY THE BOARD OF COUNTY COMMISSIONERS OF WARREN COUNTY, OHIO DO HEREBY APPROVE THIS PLAT ON THIS _____ DAY OF _____ 20____
 COMMISSIONERS: _____

CITY APPROVAL:
 CITY OF SOUTH LEBANON CLERK: _____
 DATE: _____

COUNTY RECORDER:
 FILE NO. _____
 RECEIVED THIS _____ DAY OF _____ 20____ AT _____ A.M./P.M.
 RECORDED THIS _____ DAY OF _____ 20____ AT _____ A.M./P.M.
 RECORDED IN PLAT BOOK NO. _____ PAGE _____
 REC. _____

BY: _____ WARREN COUNTY RECORDER
 COUNTY AUDITOR:
 TRANSFERRED THIS _____ DAY OF _____ 20____
 BY: _____ WARREN COUNTY AUDITOR

EX. CITY OF SOUTH LEBANON CORP.
 AREA TO BE ANNEXED TO THE CITY OF SOUTH LEBANON
**TOTAL AREA IN PROPOSED ANNEXATION:
 0.8459 ACRES ±**

ACREAGE BREAKDOWN (BASED ON RECORDS AND SHOULD BE CONSIDERED APPROXIMATE):

PARCEL	OWNER	DEED/FILE NO.	ACRES
16-11-205-017	BEAVER CREEK SITE MANAGEMENT, LLC	DOG. NO. 4033-010021	0.476 AC.
16-11-205-018	BEAVER CREEK SITE MANAGEMENT, LLC	DOG. NO. 4023-010021	0.235 AC. (SITE 2 STRIKER ROAD PLAT, P.B. 52, PP. 43-44)
			0.011 AC. (PART OF DEDICATED R/W IN P.B. 52, PP. 43-44)
			0.8459 AC. TOTAL

PERIMETER OF PROPOSED ANNEXATION AREA = 2515.1 FEET
 CONTIGUOUS, CONTIGUOUS BOUNDARY WITH CITY OF SOUTH LEBANON = 536.80 FEET
 CONTIGUOUS WITH CITY OF SOUTH LEBANON = 467.2 FEET

RECORDS ARE BASED ON THE SUBJECT PROPERTY RECORDS PLAT RECORDED IN P.B. 52, PP. 43-44, AS CAPTURED BY THE WARREN COUNTY PUBLIC RECORDS OFFICE. THIS PLAT WAS PREPARED FROM EXISTING DEEDS, MAPS AND SURVEYS OF RECORD. NOTICE OF RECORDS AND SURVEYS IS THE BASIS OF A FIELD SURVEY.
 RICHARD O. NICHOLS
 12/30/23
 DIED PROFESSIONAL SURVEYOR No. 708



**PLAT OF ANNEXATION
 CITY OF SOUTH LEBANON
 "STRIKER ROAD AREA"**
 MILITARY SURVEY NUMBER 1548
 HAMILTON TOWNSHIP, WARREN COUNTY, OHIO

Date: 13 JUL 2023
 Scale: 1" = 200'
 Drawn by: chm
 Project No.: 1548
 Survey Reference: N/D
 DWG: 1548023-000020
 Project Number: 1548-02
 Revision: 1/1

MSP
 DESIGN
 McGill Smith Punshon

1548023-000020-01.dwg, 12/30/23, 11:58:33 AM, 1548023-000020-01.dwg, 12/30/23, 11:58:33 AM, 1548023-000020-01.dwg

DESCRIPTION FOR: CITY of SOUTH LEBANON
ANNEXATION

LOCATION: "STRIKER ROAD AREA"
0.8459 Acres

Situate in Military Survey Number 1548, Hamilton Township, Warren County, Ohio and including all of Lots 1 and 2 of the Striker Road Plat recorded in Plat Book 91, Pages 43-44 (all records of the Warren County, Ohio Recorder's Office) as conveyed to Beaver Creek Site Management, LLC by deed recorded in Document Number 2023-016021 and also including 0.0316 ac. of right-of-way dedicated to the Warren County Commissioners on said plat and being more particularly described as follows:

Beginning at the northeast corner of said Lot 2 in the existing corporation line of the City of South Lebanon and west line of the original 77 acre (64.25 acre net) tract as conveyed to Terry L. Irwin, Trustee and Lea F. Irwin, Trustee of the Irwin Family Living Trust dated July 18, 2016 by deed recorded in Document Number 2018-029037;

Thence with said corporation line, along the west line of said Irwin tract, South 01°04'16" East, 536.80 feet to the north line of Lot 30 Open Space of Willow Grove recorded in Plat Book 51, Pages 94-95 as conveyed to Heartland, Ltd., LLC by deed recorded in Official Record 1976, Page 830;

Thence, along the north line of said Lot 30 Open Space, South 88°53'59" West, 116.31 feet to an east line of Striker Road (R/W Varies) as shown on the aforesaid Striker Road Plat;

Thence in part along east lines of said Striker Road, with the west line of aforesaid Lot 1 and extension thereof, crossing said right-of-way of Striker Road and with the west line of aforesaid Lot 2, North 08°59'56" East, 545.43 feet to the northwest corner of said Lot 2;

Thence continuing along said right-of-way of Striker Road, with the north line of said Lot 2, North 88°55'44' East, 20.97 feet to the point of beginning.

Containing 0.8459 acres of land, more or less.

Subject to all legal highways, easements and restrictions of record.

The above description is the result of a Plat of Annexation by McGill Smith Punshon, Inc. under the direction of Richard D. Nichols, P.S. No. 7929, dated the 14th of July 2023. The bearings in the above description are based on the subject property record plat recorded in Plat Book 91, Pages 43-44, records of the Warren County, Ohio Recorder's Office.

Prepared by: McGill Smith Punshon, Inc.

Date: 31 AUG 2023

MSP No.: 16448.02

16448023-LEG-ANX-00

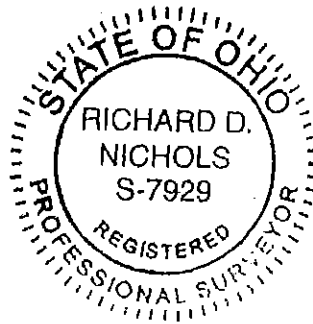

Richard D. Nichols
10/30/23

RECEIVED

CITY OF SOUTH LEBANON, OHIO
RESOLUTION NO. 2023-45

2023 NOV 21 AM 8:51

CITY OF SOUTH LEBANON, OHIO
CITY CLERK

A RESOLUTION REGARDING INCOMPATIBLE LAND USES AND ZONING BUFFER WITH RESPECT TO .8143+/- ACRES OF REAL PROPERTY PROPOSED TO BE ANNEXED TO THE CITY OF SOUTH LEBANON, OHIO, FROM ADJACENT LAND REMAINING IN HAMILTON TOWNSHIP, WARREN COUNTY, AND DECLARING AN EMERGENCY

WHEREAS, pursuant to R.C. 709.023, real estate consisting of .8143+/- acres of real property was identified in a petition for annexation ("Striker Property Annexation") filed with the Board of County Commissioners of Warren County, Ohio, on November 6, 2023, notice of such filing which, along with a copy of the petition, its attachments and documents accompanying the petition as filed were duly served upon the City of South Lebanon as prescribed by law and are on file with the City Clerk; and

WHEREAS, R.C. 709.023(C) also requires that a municipal corporation to which land is proposed to be annexed shall, by ordinance or resolution, require buffers separating any new uses in the territory annexed that the city determines are clearly incompatible with the uses under the current township or county zoning regulations, from the adjacent land remaining within the township; and

WHEREAS, R.C. 709.023(C) requires council to adopt a resolution indicating such services within twenty (20) days after the date the petition is filed; and

WHEREAS, immediate action is required to assure the City complies with its statutory duties and the statutory requirement that this resolution be adopted and submitted to the Board of County Commissioners within the timeframe specified in the Ohio Revised Code, and such action is necessary in order to preserve the public peace, health, safety or welfare of the City.

NOW, THEREFORE, BE IT RESOLVED by the Council of the City of South Lebanon, Ohio, at least two-thirds of all members elected thereto concurring:

Section 1. In the event the above-referenced .8143+/- acres of real property known as the "Striker Property Annexation" are annexed to the City of South Lebanon from Hamilton Township, Warren County, Ohio and the territory becomes subject to municipal zoning and the municipal zoning permits uses in the annexed territory that the City of South Lebanon determines are clearly incompatible with uses permitted under Warren County or Hamilton Township

zoning in effect at the time of the filing of the petition on the land adjacent to the annexation territory and remaining in Hamilton Township, then the City of South Lebanon will require, in the zoning ordinance permitting such incompatible uses, that the owner of the annexed territory provide a buffer separating the use of the annexed territory and the adjacent land remaining in Hamilton Township.

Section 2. For purposes of this annexation, "buffer" includes, but is not limited to, open space, landscaping, fences, walls, and other structured elements; streets and rights-of-way; and bicycle and pedestrian paths and sidewalks.

Section 3. The Clerk is directed to provide a certified copy of this Resolution to the Board of County Commissioners of Warren County, Ohio for filing within 20 days after the filing of the petition for annexation.

Section 4. That the recitals contained within the Whereas Clauses set forth above are incorporated by reference herein.

Section 5. For all of the reasons stated herein, this Resolution is hereby declared to be an emergency measure in accordance with Ohio Rev. Code § 731.30 for the immediate preservation of the public peace, health, safety and general welfare; and this Resolution shall be in full force and effective immediately upon its passage.

Section 6. That it is found and determined that all formal actions of the Council concerning and relating to the adoption of this Resolution were adopted in an open meeting of Council in compliance with all legal requirements, including Section 121.22 of the Ohio Revised Code.

Adopted this 16th day of November, 2023.

Attest: 
Petrina D. Williams, Director of Finance/Clerk

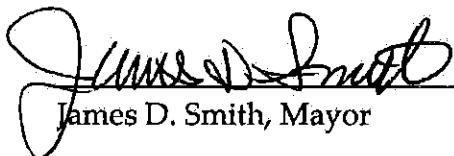

James D. Smith, Mayor

Rules Suspended: 11/16/2023 (if applicable)	Effective Date - 11/16/2023
Vote - <u>0</u> Yeas ___ Nays	
First Reading - / /2023 Second Reading - / /2023	Effective Date - / /2023
Vote - ___ Yeas ___ Nays	

Prepared by and approved as to form:

ANDREW P. MEIER
LAW DIRECTOR
SOUTH LEBANON, OHIO

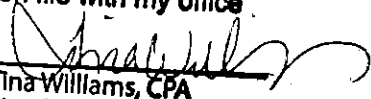
By: 
Date: 11/16/2023

CERTIFIED ORIGINAL
I, Tina Williams, CPA, Fiscal Officer of the City of South Lebanon, Ohio do hereby certify this to be the true and accurate copy of a document on file with my office.
11/20/23 
Date Tina Williams, CPA
Fiscal Officer
City of South Lebanon, Ohio